



KB2LJJ

Radio Mods Database

iCOM

**SERVICE
MANUAL**

HF ALL BAND TRANSCEIVER

IC-725

Icom Inc.

INTRODUCTION

This service manual describes the latest service information for the **IC-725** HF ALL BAND TRANSCEIVER at the time of going to press.

If you require assistance or further information regarding the operation and capabilities of the **IC-725**, contact your nearest authorized Icom Dealer or Icom Service Center.

DANGER

NEVER connect the transceiver to an AC outlet or to a DC power supply that uses more than 16 V. This will ruin the transceiver.

DO NOT expose the transceiver to rain, snow or any liquids.

DO NOT reverse the polarities of the power supply when connecting the transceiver.

DO NOT apply an RF signal of more than 20 dBm (100 mW) to the antenna connector. This could damage the transceiver's front end.

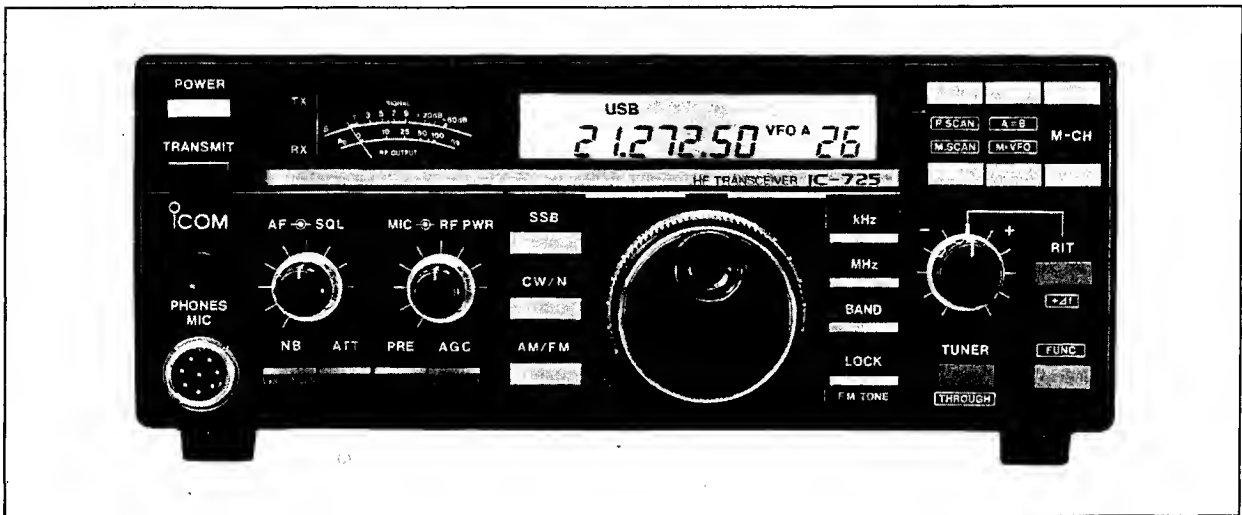

ORDERING PARTS

Be sure to include the following four points when ordering replacement parts:

1. 10-digit order numbers
2. Component part number and name
3. Equipment model name and unit name
4. Quantity required

<SAMPLE ORDER>

1110001310 IC μPC577HA IC-725 MAIN UNIT 5 pieces
8810005510 Screw PH M3 x 6 ZK BS IC-725 Top cover 10 pieces

Addresses are provided on the inside back cover for your convenience.

REPAIR NOTE

1. Make sure a problem is internal before disassembling the transceiver.
2. **DO NOT** open the transceiver until the transceiver is disconnected from a power source.
3. **DO NOT** force any of the variable components. Turn them slowly and smoothly.
4. **DO NOT** short any circuits or electronic parts. An insulated tuning tool **MUST** be used for all adjustments.
5. **DO NOT** keep power ON for a long time when the transceiver is defective.
6. **DO NOT** transmit power into a signal generator or a sweep generator.
7. **ALWAYS** connect a 40 dB~50 dB attenuator between the transceiver and a deviation meter or spectrum analyzer when using such test equipment.
8. **READ** the instructions of test equipment thoroughly before connecting equipment to the transceiver.

TABLE OF CONTENTS

SECTION 1	SPECIFICATIONS	1-1
SECTION 2	INSIDE VIEWS	2-1~2
SECTION 3	BLOCK DIAGRAM	3-1
SECTION 4	CIRCUIT DESCRIPTION	4-1~7
4-1	RECEIVER CIRCUITS	4-1
4-2	TRANSMITTER CIRCUITS	4-4
4-3	PLL CIRCUITS	4-6
4-4	LOGIC CIRCUITS	4-7
4-5	REGULATOR CIRCUITS	4-7
SECTION 5	MECHANICAL PARTS AND DISASSEMBLY	5-1~7
5-1	FRAME DISASSEMBLY	5-1
5-2	PA UNIT AND ACCESSORIES	5-3
5-3	FRONT AND PLL UNITS CONNECTOR ASSEMBLY	5-5
5-4	FRONT AND MAIN UNITS CONNECTOR ASSEMBLY	5-6
5-5	PA AND FILTER UNITS CONNECTOR ASSEMBLY	5-7
SECTION 6	ADJUSTMENT PROCEDURES	6-1~7
6-1	PREPARATION BEFORE SERVICING	6-1
6-2	PLL ADJUSTMENT	6-2
6-3	RECEIVER ADJUSTMENT	6-4
6-4	TRANSMITTER ADJUSTMENT	6-6
SECTION 7	BOARD LAYOUTS	7-1~5
7-1	FRONT UNIT	7-1
7-2	MAIN UNIT	7-2
7-3	PLL UNIT	7-3
7-4	PA UNIT	7-4
7-5	DDS UNIT	7-5
7-6	AM • FM UNIT (OPTIONAL)	7-5
SECTION 8	PARTS LIST	8-1~13
SECTION 9	VOLTAGE DIAGRAMS	9-1~2
9-1	FRONT AND MAIN UNITS	9-1
9-2	PLL AND PA UNITS	9-2

SECTION 1 SPECIFICATIONS

GENERAL

- Frequency coverage : Receive 500 kHz~30 MHz
 Transmit 160-m band 1.8~ 2.0 MHz 17-m band 18.068~18.168 MHz
 80-m band 3.5~ 4.0 MHz 15-m band 21.0 ~21.45 MHz
 40-m band 7.0~ 7.3 MHz 12-m band 24.89 ~24.99 MHz
 30-m band 10.1~10.15 MHz 10-m band 28.0 ~29.7 MHz
 20-m band 14.0~14.35 MHz
- Modes : SSB (A3J), CW (A1), AM (A3), FM (F3)
 (UI-7 AM · FM UNIT is required for AM transmit and FM transmit/receive.)
- Number of memory channels : 26
- Antenna impedance : 50 Ω unbalanced
- Usable temperature range : $-10^{\circ}\text{C}\sim+60^{\circ}\text{C}$ ($+14^{\circ}\text{F}\sim+140^{\circ}\text{F}$)
- Frequency stability : Less than ± 200 Hz up to one hour after power is turned ON.
 Less than ± 30 Hz after one hour at $+25^{\circ}\text{C}$ ($+77^{\circ}\text{F}$).
 Less than ± 350 Hz at $0^{\circ}\text{C}\sim+50^{\circ}\text{C}$ ($+32^{\circ}\text{F}\sim+122^{\circ}\text{F}$).
- Power supply requirement : 13.8 V DC $\pm 15\%$, negative ground
- Current drain (at 13.8 V DC) : Receive squelched 1.2 A max. audio output 1.5 A
 Transmit 20 A
- Dimensions : 241 (W) \times 94 (H) \times 239 (D) mm (Projections not included)
 9.5 (W) \times 3.7 (H) \times 9.4 (D) in
- Weight : 4.6 kg (10.1 lb)

TRANSMITTER

- Output power : SSB, CW, FM 10~100 W continuously adjustable
 AM 10~40 W continuously adjustable
- Spurious emissions : More than 50 dB below peak output power
- Carrier suppression : More than 40 dB below peak output power
- Unwanted sideband : More than 50 dB down with 1 kHz AF input
- Microphone impedance : 600 Ω

RECEIVER

- Receive system : SSB, CW, AM Double-conversion superheterodyne
 FM Triple-conversion superheterodyne
- Intermediate frequencies : 1st SSB 70.4515 MHz
 CW 70.4506 MHz
 AM, FM 70.4500 MHz
 2nd SSB 9.0115 MHz
 CW 9.0106 MHz
 AM, FM 9.0100 MHz
 3rd FM 455 kHz
- Sensitivity (preamplifier ON) : SSB, CW (10 dB S/N) 1.8~30 MHz Less than 0.15 μV (-123 dBm)
 AM (10 dB S/N) 0.5~1.8 MHz Less than 13.0 μV (-85 dBm)
 1.8~30 MHz Less than 2.0 μV (-101 dBm)
 FM (12 dB SINAD) 28~30 MHz Less than 0.5 μV (-113 dBm)
- FM squelch sensitivity : Less than 0.3 μV (preamplifier ON)
- Selectivity : SSB, CW More than 2.3 kHz/ -6 dB Less than 4.0 kHz/ -60 dB
 AM More than 6.0 kHz/ -6 dB Less than 20.0 kHz/ -40 dB
 FM More than 15 kHz/ -6 dB Less than 30 kHz/ -50 dB
- Spurious response rejection : More than 70 dB
- Audio output impedance : 8 Ω
- Audio output power : More than 2.6 W at 10 % distortion with an 8 Ω load
- RIT variable range : More than ± 1 kHz

All stated specifications are subject to change without notice or obligation.

SECTION 2 INSIDE VIEWS

• PLL UNIT

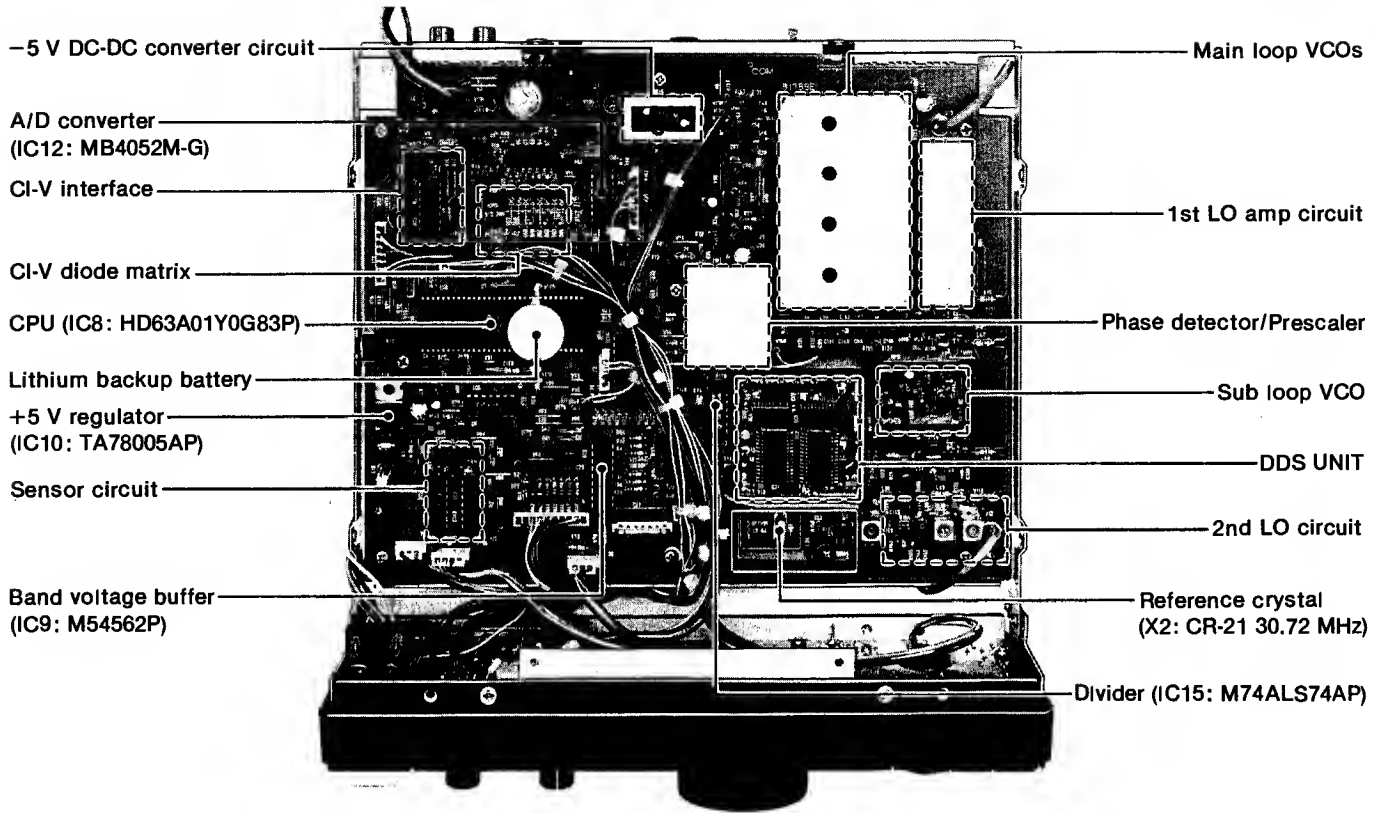

• MAIN UNIT

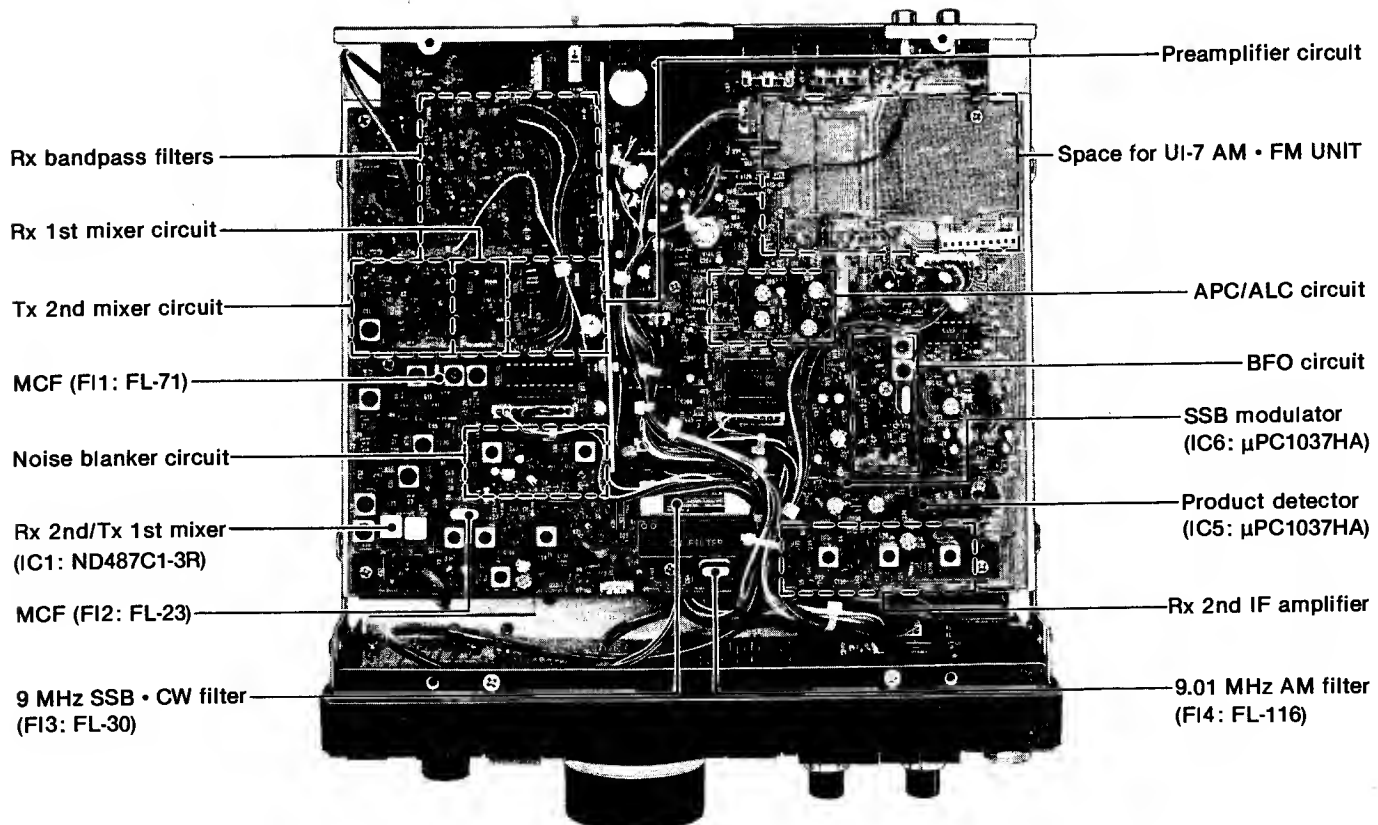

• PA AND FILTER UNITS

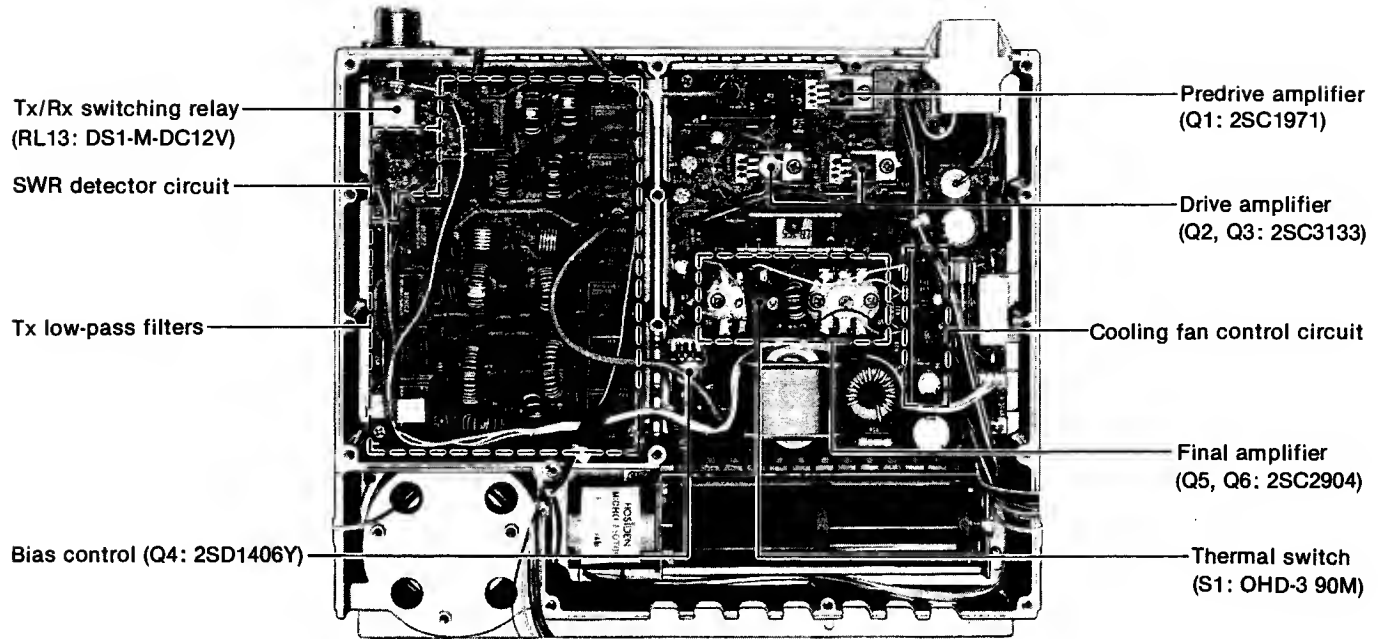

SECTION 3 BLOCK DIAGRAM

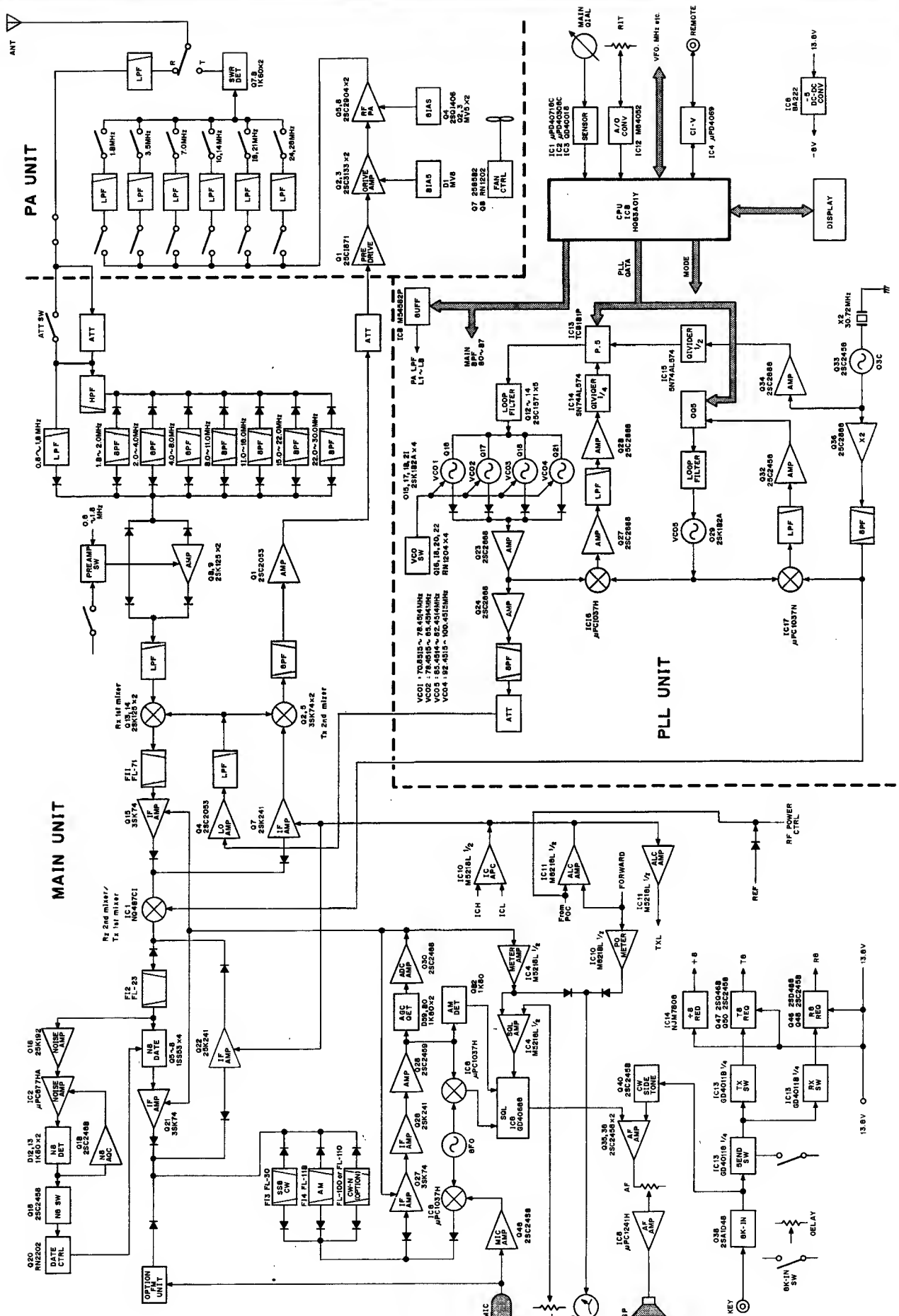

SECTION 4 CIRCUIT DESCRIPTION

4-1 RECEIVER CIRCUITS

4-1-1 RF SWITCHING CIRCUIT (PA AND MAIN UNITS)

RF signals from the antenna connector pass through the transmit/receive switching relay (RL13) and a low-pass filter, and are applied to the MAIN UNIT via P2 (MAIN UNIT: J12).

The signals from the PA UNIT either bypass or are attenuated at 20 dB attenuator (R102, R103, RL1). There are no non-linear components between the antenna connector and attenuator to prevent distortion caused by strong signals. The signals are then applied to RF filters.

4-1-2 RF BANDPASS FILTER CIRCUIT (MAIN UNIT)

The RF UNIT has 7 RF bandpass filters (BPF) for signals above 1.6 MHz and 1 low-pass filter (LPF) for signals below 1.6 MHz. The signals pass through one of the bandpass or low-pass filters depending on the receive frequency range.

(1) 0.5~1.6 MHz

A diode is not used at the low-pass filter entrance removing diode distortion from very strong signals. Signals bypass a preamplifier by the bypass switch (Q12).

(2) 1.6 MHz AND ABOVE

Signals are applied to a high-pass filter consisting of L42, L43, C143~C146. This filter suppresses strong signals below 1.6 MHz such as a broadcasting station.

The filtered signals are applied to one of 7 bandpass filters depending on the frequency of the signals and then to the preamplifier circuit (Q8, Q9).

(3) FILTER SWITCHING CIRCUIT

An RF bandpass filter is selected with BPF switching voltage (B0~B7) from the CPU via IC16 current amplifier. The switching voltage of the BPF entrance is higher than the BPF exit to improve multi-signal and strong signal characteristics.

4-1-3 PREAMPLIFIER CIRCUIT (MAIN UNIT)

The preamplifier circuit uses low-noise junction FETs (2SK125×2) to provide 10 dB gain over a wideband frequency range.

When the [PRE] switch is turned ON, the signals from the RF filter are amplified by the preamplifier circuit (Q8, Q9). When the [PRE] switch is turned OFF, the signals bypass the preamplifier through D30 and D32. When the operating frequency is below 1.6 MHz, Q12 turns ON and the signals bypass the preamplifier regardless of the [PRE] switch.

Amplified or bypassed signals are applied to the 1st mixer circuit via the low-pass filter. The low-pass filter cuts off at 35 MHz to suppress image frequency at the 1st mixer circuit (Q13, Q14).

PREAMP CIRCUIT

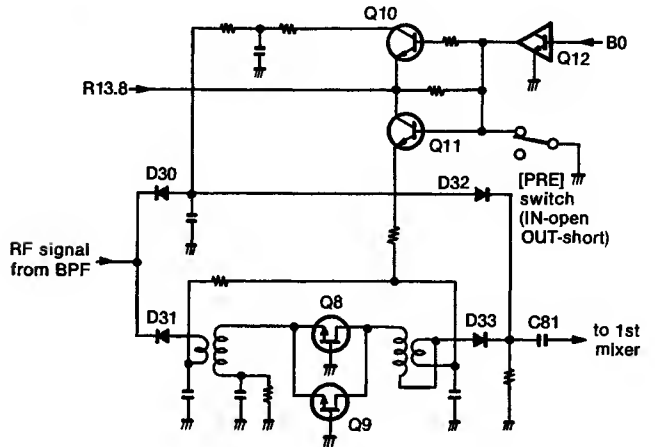

Fig. 1

4-1-4 1ST MIXER CIRCUITS (MAIN UNIT)

The signals from the low-pass filter enter the 1st mixer circuit (Q13, Q14) to be converted to a 70.45 MHz 1st IF signal.

EXACTNESS 1ST IF FREQUENCY

MODE	FREQUENCY (MHz)
SSB	70.4515
CW	70.4506
AM, FM	70.4500

The 1st mixer circuit employs a balanced mixer using low-noise junction FETs (2SK125×2) to expand the dynamic range.

The 1st LO signal (70.9515~100.4515 MHz) enters the MAIN UNIT from the PLL UNIT via J5. The signal is amplified at Q4, filtered by a low-pass filter, and then applied to the 1st mixer circuit (Q13, Q14). The low-pass filter employs a ring core inductor to prevent 1st LO leakage signals. The output level from Q4 is approx. 25 dBm.

The 1st IF signal is applied to an MCF (Monolithic Crystal Filter; F11) to suppress out-of-band signals. The signal is amplified at the 1st IF amplifier (Q15), and then applied to the 2nd mixer (IC1).

4-1-5 IF CIRCUITS (MAIN UNIT)

The 1st IF signal from Q15 is converted to a 9 MHz 2nd IF signal at the 2nd mixer (IC1). IC1 is a DBM (Double Balanced Mixer).

EXACTNESS 2ND IF FREQUENCY

MODE	FREQUENCY (MHz)
SSB	9.0115
CW	9.0106
AM, FM	9.0100

The 2nd LO signal (61.44 MHz) from the PLL UNIT via J4 is applied to the 2nd mixer. The converted 2nd IF signal passes through D4 (D35 for transmitting) and is applied to the MCF (FI2) to suppress unwanted signals.

The signal output from FI2 passes through the noise blanker gate (D5~D8) and is amplified at the 2nd IF amplifier (Q21). The signal enters one of the three 9 MHz filters (FI3, FI4, optional CW narrow filter) or optional AM · FM UNIT via D52. The filters are selected with mode selecting signals (SSB · CW, AM, CW-N) and the "T8" voltage line.

The signal from a 9 MHz filter is amplified at the 2nd IF amplifiers (Q27~Q29) and applied to the demodulator circuit.

Dual-gate FETs are used on the 1st and 2nd IF amplifiers (Q15, Q21, Q27). The 2nd gates of Q15, Q21 and Q27 are controlled by AGC bias voltage. A rapid time constant is used for Q27 to prevent raising the edge distortion of receive signals.

R140, connected to the gate of Q28, improves the temperature characteristics of the receiver gain. R138 adjusts the receiver gain.

4-1-6 NOISE BLANKER CIRCUITS (MAIN UNIT)

The IC-725 uses a noise trigger noise blanker circuit that cuts out pulse-type noise signals at the noise blanker gate (D5~D8).

A portion of the signals from FI2 is amplified at the noise amplifiers (Q16, IC2) and detected at the noise detector (D12, D13). The detected voltage from the noise detector is applied to the noise blanker switch (Q19).

The threshold level of the noise blanker switch is set at 0.9 V. When the detected voltage exceeds the threshold level, Q20 outputs a blanking signal to activate the noise blanker gate (D5~D8).

A portion of the detected voltage is applied to the noise AGC circuit (Q18) and fed back to the noise amplifier (IC2) as noise AGC voltages. The time constant of the noise AGC circuit is determined by R43, R47 and C60. This AGC circuit does not operate to detect pulse-type noise.

When the operating frequency or mode is changed, the "DNB" signal line becomes "LOW," turning Q20 ON. The noise blanker gate prevents PLL click noise.

4-1-7 BFO CIRCUIT (MAIN UNIT)

A 9 MHz signal oscillated at the BFO circuit (Q31, X1) is buffer-amplified at Q42 and used at the balanced modulator (IC6) and a product detector (IC5).

In USB mode, the "USB" signal line becomes "HIGH," turning ON D69. The frequency is then adjusted with C294 to set the USB carrier point.

At CW mode transmitting, the "CW" signal line becomes "HIGH" and Q33 becomes OFF, turning ON D68. The frequency is then adjusted with L83 to set the CW transmit carrier point.

In LSB mode, the "LSB" signal line becomes "HIGH," turning ON D67. The frequency is then adjusted with L82 to set the LSB carrier point.

IF CIRCUIT

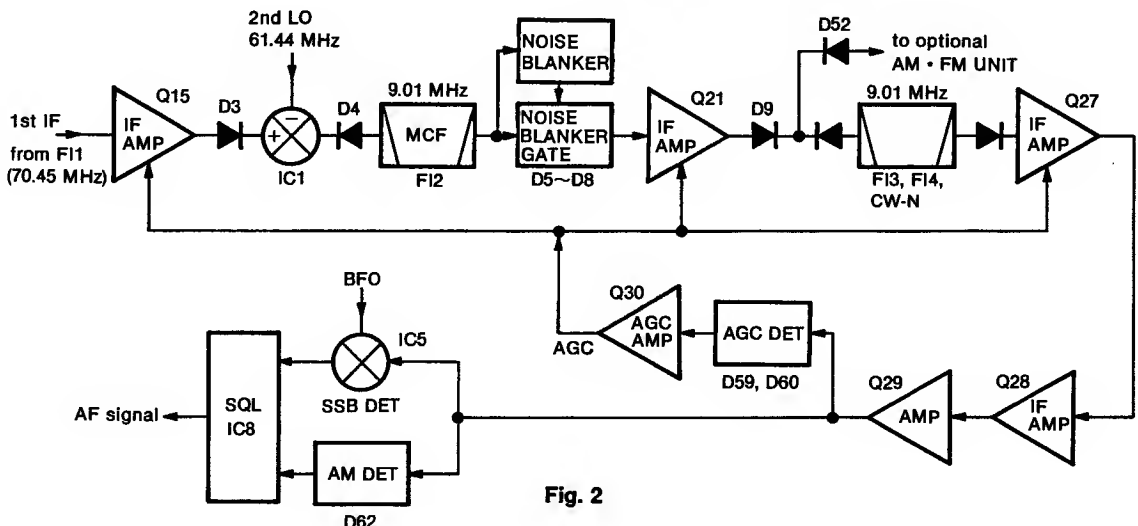

Fig. 2

BFO FREQUENCY IN EACH MODE

MODE	FREQUENCY (MHz)
USB	9.0130
CW (Tx)	9.0106
LSB	9.0100
CW (Rx)	9.0098
AM	NO OUTPUT

4-1-8 DEMODULATOR CIRCUITS (MAIN UNIT)

The IC-725 has 2 detector circuits, a product detector and a diode detector to demodulate the SSB, CW signal and AM signal respectively.

In SSB or CW mode, the 2nd IF signal from the IF amplifier (Q29) is mixed with the BFO signal at the product detector (IC5) to demodulate the 2nd IF signal into an AF signal. The detected signal passes through the AF input mode selector switch (IC8).

In AM mode, the 2nd IF signal from Q29 passed through C121 is detected at D62 and passes through the AF input mode selector switch (IC8).

4-1-9 AF INPUT MODE SELECTOR SWITCH (MAIN UNIT)

The AF signal from a detector circuit or the optional AM · FM UNIT is applied to the AF input mode selector switch (IC8). IC8 consists of 4 analog switches and they are selected with a mode signal from IC15 and the squelch control signal. The AF signal is applied to the AF amp circuit.

IC8 AF INPUT MODE SELECTOR SWITCH

MODE	ACTIVATING PIN NUMBERS	CONTROL PIN NUMBER
USB, CW	2 → 1	13
AM	3 → 4	5
FM	10 → 11	12
ANY MODES (for S-meter)	9 → 8	6

4-1-10 AF AMP CIRCUIT (MAIN UNIT)

The AF signal from the AF input mode selector switch is applied to the AF preamplifier (Q35, Q36). The CW sidetone signal is applied to Q36.

The output from the AF preamplifier is applied to the [AF] control (FRONT UNIT, R1b) and the 2.8 kHz cut-off active low-pass filter (Q37). The AF signal is power-amplified at IC9 to drive the speaker.

4-1-11 AGC AND S-METER CIRCUIT (MAIN UNIT)

The receiver gain is determined by the voltage on the AGC line (Q30, collector). When strong signals are received, the AGC circuit decreases the voltage on this line.

The IF signal from the IF amplifier (Q29) passes through C117, is detected at D59 and D60, and applied to the base of Q30. A time constant (C113, R120) is connected to the AGC line that determines the AGC release time.

The time constant is controlled by the [AGC] switch. When the [AGC] switch is pushed OUT, C112 and R119 are connected in parallel with the AGC line to obtain a slow AGC release time.

The AGC bias voltage is applied to the differential amplifier (IC4, pin 6) where the difference between the bias and reference voltages is detected. The resulting S-meter signal passes through the meter switching circuit (IC8) and is then applied to the meter on the front panel. The reference voltage is adjusted with R116. IC8 pins 8 and 9 are connected inside the IC in receiving.

The FM S-meter signal from the optional AM · FM UNIT is applied to the meter switching circuit (IC8) via D57. The signal is also applied to the squelch circuit (IC4 pin 2).

AGC, S-METER AND SQUELCH CIRCUIT

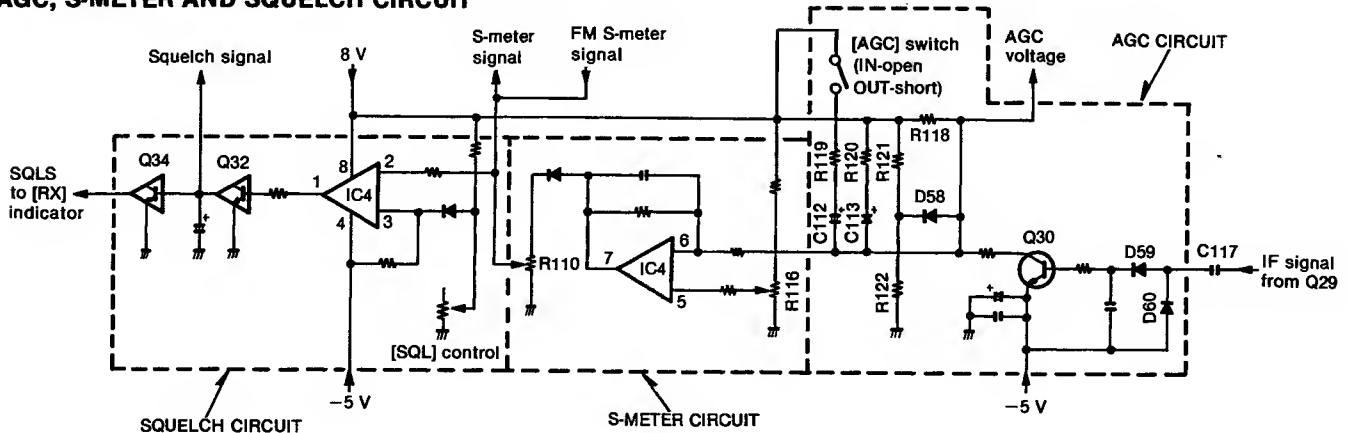

Fig. 3

4-1-12 SQUELCH CIRCUIT (MAIN UNIT)

The squelch circuit mutes the audio output when the S-meter signal is lower than the [SQL] control setting level.

The S-meter signal from IC4 pin 7 is applied to the comparator (IC4 pin 2) to be compared to a threshold level controlled by the [SQL] control. The squelch control signal is applied to control terminals of the AF input mode selector switch (IC8).

When the S-meter signal is lower than the threshold level, the comparator turns "HIGH" and then Q32 turns OFF to deactivate the AF input mode selector switch. This signal is applied to Q34, turning OFF the [RX] indicator and is also applied to the [MIC] connector pin 4.

4-2 TRANSMITTER CIRCUITS

4-2-1 MIC AMPLIFIER (MAIN UNIT)

Audio signals from the [MIC] connector are applied to the [MIC] control and amplified at the mic amplifier (Q45). External modulation input from the [ACC(1)] socket pin 4 is also applied to Q45 via R255.

The AF signals from Q45 or CW keying signal is applied to the balanced modulator (IC6). Q44 cuts the signals from Q45 in CW or receiving.

4-2-2 BALANCED MODULATOR (MAIN UNIT)

Output signals from the mic amplifier or CW keying signal are applied to the balanced modulator circuit (IC6) to be converted to a 9 MHz IF signal using a BFO signal. The BFO signal, buffer-amplified at Q42, is applied to IC6 pin 7 as a carrier signal. IC6 outputs a double sideband signal and passes through a 9 MHz filter to create an SSB signal.

R177 and R179 adjust the balance level of IC6 for maximum carrier suppression. In CW mode, the CW keying signal upsets the balance to create a carrier signal.

4-2-3 IF CIRCUITS (MAIN UNIT)

The 9 MHz IF signal passes through one of the three 9 MHz filters where unwanted sideband or out-of-band signals are removed. The filters are selected with mode selecting signals and the "T8" voltage line. The optional CW narrow filter is not used in transmitting.

The resulting signal is amplified at Q22, and is then mixed with the 2nd LO signal to be converted to a 70.45 MHz IF signal at IC1. IC1 is used in receiving and transmitting. The FM signal from the optional AM · FM UNIT is amplified at Q22 and is then applied to IC1.

The 70.45 MHz IF signal is amplified at the IF amplifier (Q7) and is then converted to the displayed frequency at the balanced mixer (Q2, Q3).

The gates of the IF amplifiers (Q7, Q22) are controlled by ALC bias voltage from the ALC circuit. R89, connected to the gate of Q22, improves the temperature characteristics of the transmitter gain. R85 adjusts the transmitter gain.

4-2-4 RF CIRCUITS (MAIN AND PA UNITS)

The converted signal from Q2 and Q3 is applied to the bandpass filter where the unwanted LO signal emission is reduced. The converted signal is amplified at Q1, and is then applied to the PA UNIT via J11.

Incoming signals from the MAIN UNIT are amplified at the predrive amplifier (Q1), drive amplifier (Q2, Q3) and power amplifier (Q5, Q6) to obtain stable 100 W RF output power. The predrive amplifier is a class A amplifier with a Vcc of 13.8 V. The drive and power amplifiers are class AB push-pull amplifiers with a Vcc of 13.8 V. A stable bias voltage is applied to these amplifiers. D1 controls a bias voltage to the drive amplifier. Q4, D2 and D3 supply a bias voltage to the power amplifier.

A 0.012 Ω resistor (R26), inserted in the 13.8 V Vcc line, is provided for the Ic APC circuit. A voltage generated at both terminals of R26 is applied to the MAIN UNIT via the "ICH" and "ICL" signal line.

Thermal switch S1 and thermistor R32 detect the temperature of Q6 and Q5 respectively, and control the cooling fan speed.

TEMPERATURE °C (°F)		Below 50 (122)	50~90 (122~194)	Above 90 (194)
THERMAL SWITCH (S1)		OFF	OFF	ON
RESISTANCE OF R32		HIGH	LOW	LOW
COOLING FAN SPEED	RECEIVE	STOP	LOW	HIGH
	TRANSMIT	LOW		HIGH

COOLING FAN CONTROL CIRCUIT

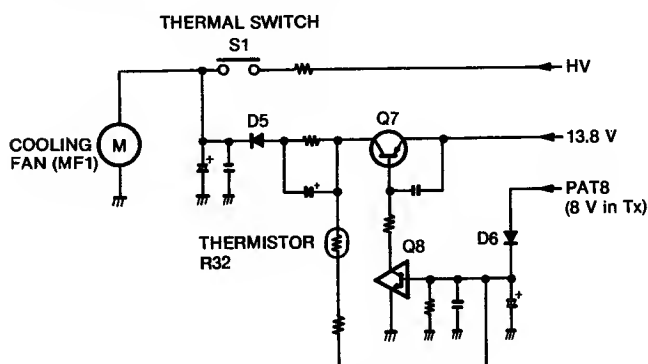

Fig. 4

4-2-5 RF FILTER CIRCUIT (PA UNIT)

The PA UNIT has 6 Chebyshev low-pass filters. The signal from the power amplifier (Q5, Q6), applied to one of the low-pass filters depending on the transmit frequency range, suppresses high harmonic components.

The filter switching voltage, obtained at the PLL UNIT, is applied to the PA UNIT via P7.

FREQUENCIES AND APPROPRIATE FILTERS

FILTER	FREQUENCY RANGE (MHz)
L1	Below 2
L2	2~4
L3	4~8
L4	8~15
L5	15~22
L6	22~30

The filtered signal passes through the SWR detector circuit (L51) and is then applied to the antenna connector. The forward signal from L51 is detected at D7 and applied to the MAIN UNIT as the "FOR" voltage. The reflection signal from L51 is detected at D8 and applied to the MAIN UNIT as the "REF" voltage.

4-2-6 ALC CIRCUIT (MAIN UNIT)

The ALC (Auto Level Control) circuit stably controls the RF output power using the [RF POWER] control.

The "FOR" voltage from the PA UNIT is applied to IC11 pin 2 and IC10 pin 3. The "POC" voltage controlled by the [RF PWR] control is also applied to IC11 pin 3 as the reference voltage.

When the "FOR" voltage exceeds the "POC" voltage, ALC bias voltage from IC11 pin 1 controls the IF amplifiers to reduce the output power until the "FOR" and "POC" voltages are equalized.

In AM mode, IC11 operates as an averaging ALC amplifier, because a capacitor on the optional AM · FM UNIT (C51) is connected to the cathode of D76. Q54 turns ON and the "POC" voltage is shifted for 40 W AM output power (maximum).

The ALC bias voltage from IC11 pin 1 is also applied to the inversion-amplifier (IC11 pin 6) to control an intensity of the [TX] indicator, showing the ALC level.

An external ALC input from the [ALC] jack is applied to the buffer amplifier (Q53). ALC operation is identical to that of the internal ALC.

4-2-7 APC CIRCUITS (MAIN UNIT)

The APC circuits protect the final transistors from high SWR and excessive current. The "REF" voltage from the PA UNIT is applied to Q56. When the "REF" voltage exceeds the reference voltage, determined by R203 and R204, Q56 turns ON and the "POC" voltage is shifted for 12 W output power.

The "ICH" and "ICL" voltages are applied to the IC APC amplifier (IC10, pins 5 and 6) and then to the ALC bias voltage line to prevent excessive current flow.

4-2-8 CW KEYING CIRCUIT (MAIN UNIT)

When the CW key is closed, the "KEY" signal line becomes "LOW." Q38 outputs 8 V to control break-in operation, sidetone signal and transmit signal.

When the [BK IN] switch is pushed IN, 8 V from Q38 charge C252 and Q26 is turned ON, turning ON Q52. Q52 grounds the SEND line for transmitting. The [DELAY] control (R244) adjusts the transmit release delay time.

The 8 V from Q38 charges C249 and D91 is turned OFF, disconnecting C249 from Q40. Q40 then oscillates a sidetone signal. R268 prevents sidetone click noise.

The 8 V from Q38 is applied to a time constant and then to the balanced modulator (IC6) to create a carrier signal. R241 in the time constant adjusts a transmit delay timing for 12 msec.

ALC CIRCUIT

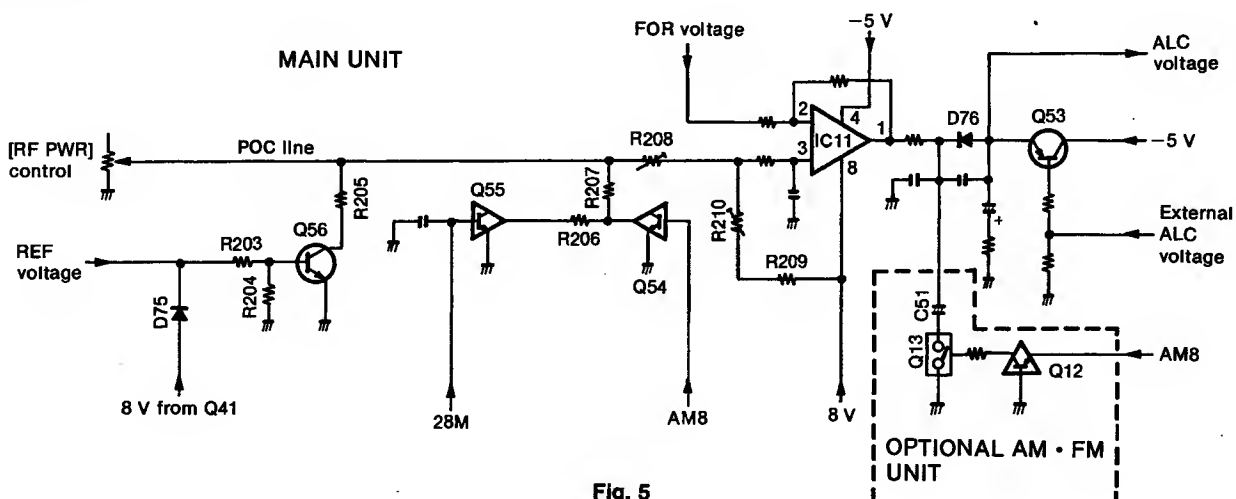

Fig. 5

While no CW transmit IF signal exists, Q39 and Q23 turn the switching diode (D35) OFF to ensure transmit isolation.

4-2-9 OUTPUT POWER METER CIRCUITS (MAIN UNIT)

The "FOR" voltage from the PA UNIT is applied to the Po meter amplifier (IC10 pin 3) and then to the meter. R189 and C261 are used for peak power measurement.

4-2-10 T/R SWITCHING CIRCUIT (MAIN UNIT)

When the PTT or [TRANSMIT] switch is set to transmit, IC13 pin 10 and IC13 pin 3 are "LOW." At this time, Q49 turns ON, and 0 V is present on the "R8" voltage line. Q50 turns OFF, and there is 8 V present on the "T8" voltage line.

When the PTT or [TRANSMIT] switch is set to receive, IC13 pin 10 and IC13 pin 3 are "HIGH." At this time, Q49 turns OFF, and 8 V is present on the "R8" voltage line. Q50 turns ON, and there is 0 V present on the "T8" voltage line.

When PLL data or the operating mode is changed, the "DNB" signal line becomes "LOW," turning OFF the T8 – preventing unwanted transmission.

4-3 PLL CIRCUITS

4-3-1 GENERAL DESCRIPTION

The PLL UNIT generates a 1st LO signal (70.9515~100.4515 MHz variable) and 2nd LO signal (61.44 MHz fixed) used in the MAIN UNIT. The IC-725 uses a dual loop PLL system. A main loop PLL uses 4 VCO circuits for all HF band coverage within 512 kHz steps. A sub loop PLL uses a DDS (Direct Digital Synthesizer) system for 512 kHz coverage within 10 Hz steps. The DDS system provides a rapid lockup time and high quality frequency oscillation.

4-3-2 REFERENCE OSCILLATOR CIRCUIT (PLL UNIT)

A 30.72 MHz reference frequency is produced by the oscillator Q33 and X2. The reference frequency, buffer-amplified at Q34, is divided by 2 at IC15 and is then applied to the PLL circuit as the PLL reference frequency.

The signal oscillated at Q33 is multiplied by 2 at Q36. The resulting 61.44 MHz signal is filtered at the bandpass filter and is then applied to the MAIN UNIT via P4 as the 2nd LO signal.

4-3-3 MAIN LOOP (PLL UNIT)

The main loop uses a PLL IC (IC13) which contains a programmable divider, phase detector, data shift register and data latch circuits. The main loop generates 70.9515~100.4515 MHz signals in 512 kHz steps.

Because the sub loop produces 10 Hz steps, the PLL produces a 30 MHz frequency range in 10 Hz steps.

The oscillated signal at one of the 4 VCOs (Q15, Q17, Q19, Q21; see Section 4-3-4 for details) is amplified at Q23. The signal is mixed with the sub loop output (f_{LO} : 62.05~62.56199 MHz) at IC16. Q23 is an isolator which ensures that the mixer input does not affect the VCO output.

The mixed signal is amplified at Q27 and is then filtered at the low-pass filter (L23~L25, C92, C93, C99~C103). The filtered signal, amplified at Q26, is divided by 4 at IC14 and is then applied to the PLL IC (IC13).

The phase of the divided signal at IC14, detected at the PLL IC (IC13) using a reference frequency (f_{REF}) of 512 kHz, is then output from pin 17. The 512 kHz frequency is obtained from the reference oscillator (Q33). 30.72 MHz oscillated at Q33, is divided by 2 at IC15 and divided by 30 at the programmable divider section of IC13.

The phase detected signal is then converted to the lock voltage at the loop filter (Q12~Q14), and applied to the VCO. Thus, the VCO output (PLL output) is locked to produce stable oscillation.

The PLL oscillation frequency is obtained by the following calculation:

$$f_V = f_{LO} + N_T \times f_{REF}$$

f_V : Main loop output
 f_{LO} : Sub loop output
 N_T : Dividing ratio from the CPU
 f_{REF} : Reference frequency (512 kHz)

4-3-4 VCO CIRCUIT (PLL UNIT)

The transceiver's C/N ratio is determined by the VCO and the loop filter. 4 VCO circuits keep the low noise and reduce spurious emissions. Q16, Q18, Q20 and Q22 are VCO switches which select the operating VCO with "VCO1"~"VCO4" lines.

4-3-5 SUB LOOP (PLL UNIT)

The sub loop uses the DDS system that generates 62.05~62.56199 MHz signals in 10 Hz steps.

The oscillated signal at the VCO (Q29) is buffer-amplified at Q30 and mixed with the 2nd LO signal (61.44 MHz) at IC17. The resulting signal passes through the low-pass filter, is amplified at Q32, and is then applied to the DDS UNIT.

The output pulse-type signal from the DDS UNIT passes through the loop filter (R133, R134, C114, C115, L42) where it is converted into a DC signal (lock voltage). The lock voltage is applied to the VCO to lock the oscillating frequency.

PLL CIRCUIT BLOCK DIAGRAM

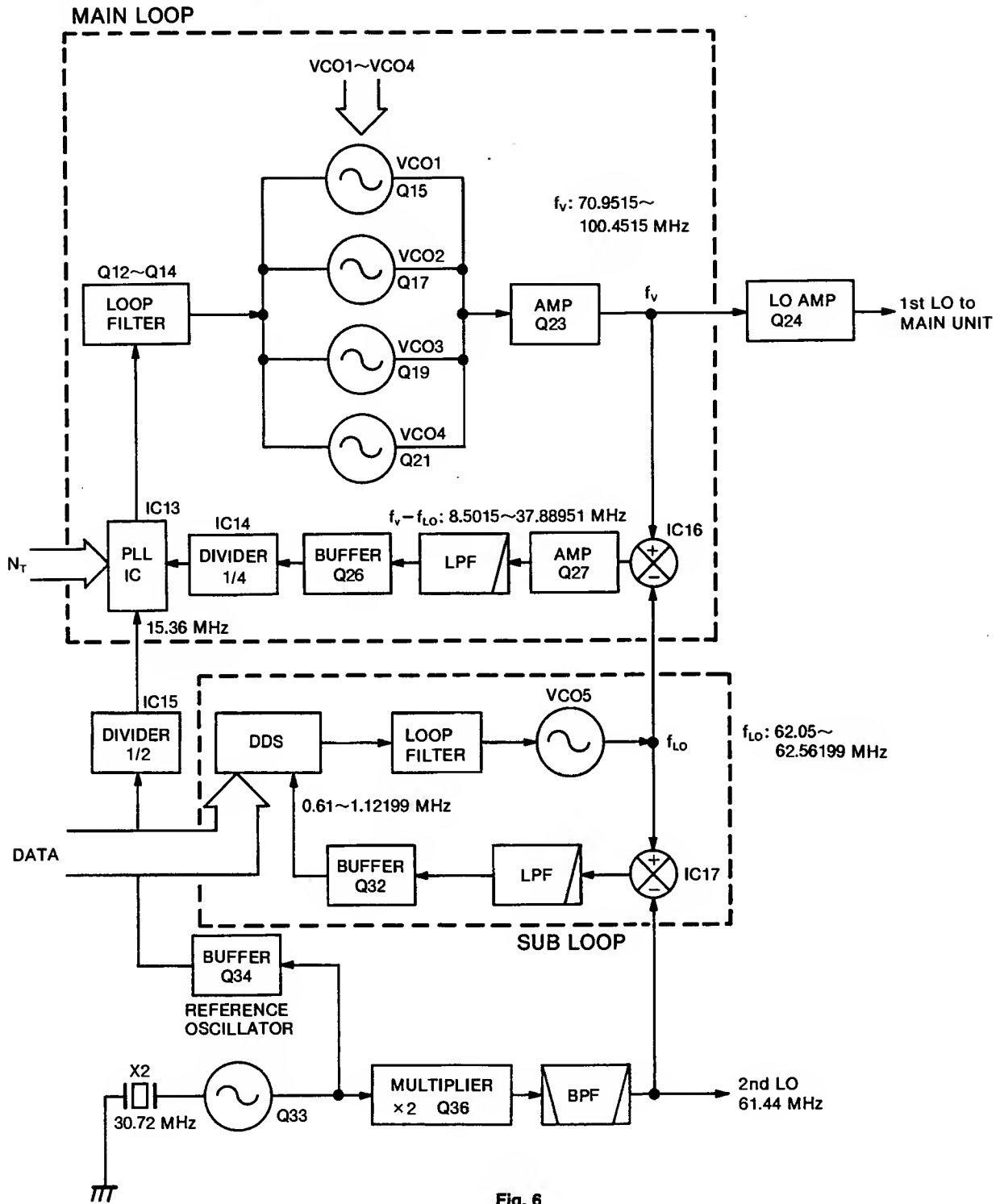

Fig. 6

4-4 LOGIC CIRCUITS

4-4-1 BAND SELECTION DATA (PLL UNIT)

To select the correct bandpass filter, the low-pass filter and VCOs on the MAIN and PLL UNITS, the CPU outputs the following data.

R29~R40 and D29~D35 convert the "B0"~"B7" signals into a band voltage (0~7.5 V) for external equipment.

FREQUENCY (MHz)	BPF	BAND VOLTAGE	LPF	VCO
0.5~1.599	B0	7.5 V	L1	VCO1
1.6~1.999	B1		L2	
2.0~3.999	B2	5.9 V	L3	
4.0~7.999	B3	5.0 V	L4	
8.0~10.999	B4	0.0 V	L4	VCO2
11.0~14.999	B5	4.1 V		
15.0~21.999	B6	3.2 V	L5	VCO3
22.0~30.0	B7	2.2 V	L6	VCO4

4-4-2 CPU (PLL UNIT)

The CPU (IC8) contains an 8-bit CMOS CPU, 16k-byte ROM and 256-byte RAM. The CPU controls operating frequency, mode and the function display, etc. The memory contents are stored in the CPU using a lithium backup battery for more than 5 years.

The Icom CI-V network system allows that the IC-725 can be remotely controlled by a personal computer using an RS-232C signal line.

4-4-3 RIT CIRCUIT (PLL UNIT)

IC12 is an A/D converter which outputs 8-bit serial data regarding analog input voltage. A voltage, controlled by the [RIT] control, is applied to IC12 pin 4 and the resulting serial data is applied to the CPU matrix Y4 → DB4.

4-4-4 KEY MATRIX

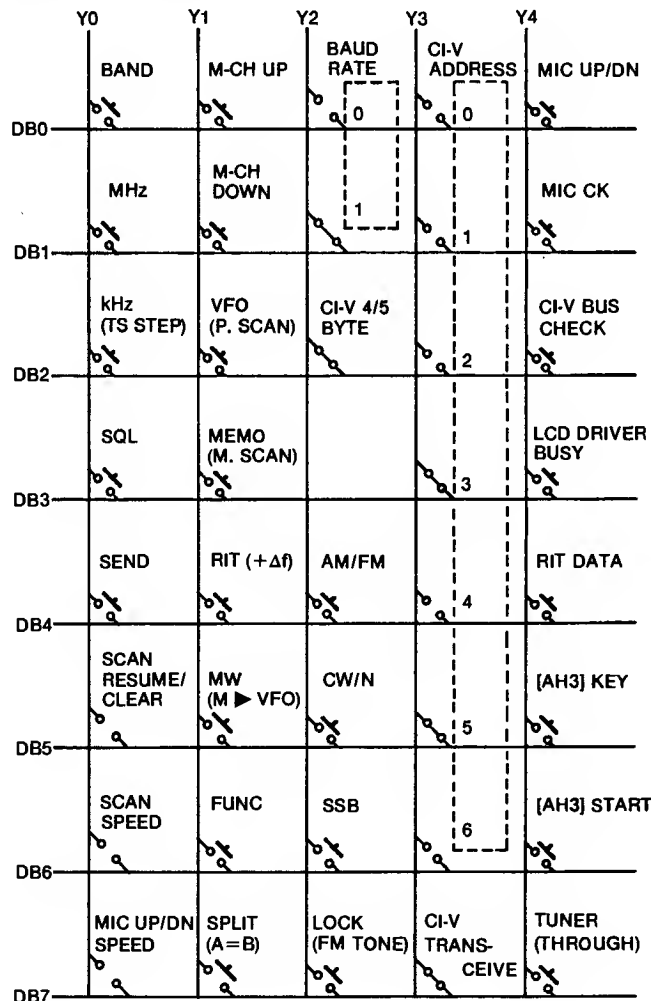

Fig. 7

4-4-5 PARALLEL/SERIAL CONVERTER (PLL UNIT)

IC11 is a parallel/serial converter IC. Parallel data from the CPU are converted into serial data to transfer the PLL N-data, DDS N-data, data for LCD driver, etc.

When the power is turned ON, the CPU also outputs programmable divider data and a control signal for universal ports to the PLL IC (IC13).

4-5 REGULATOR CIRCUITS

Either 8, 5 or -5 V DC are supplied from corresponding regulator circuits. 8, 5 and -5 V DC are regulated at the following circuits using 13.8 V DC.

(1) 5 V REGULATOR (PLL UNIT)

5 V DC are regulated by the three-terminal voltage regulator (IC10).

(2) 8 V REGULATOR (MAIN UNIT)

8 V DC are regulated by the three-terminal voltage regulator (IC14).

(3) -5 V REGULATOR (PLL UNIT)

IC6 generates a negative pulse-type voltage by converting the DC input to AC voltages (approx. 6.7 kHz) as a multivibrator. The voltage is rectified at D8 and D9, regulated by a Zener diode (D10) and C13, and is then applied to the MAIN UNIT.

SECTION 5 MECHANICAL PARTS AND DISASSEMBLY

5-1 FRAME DISASSEMBLY

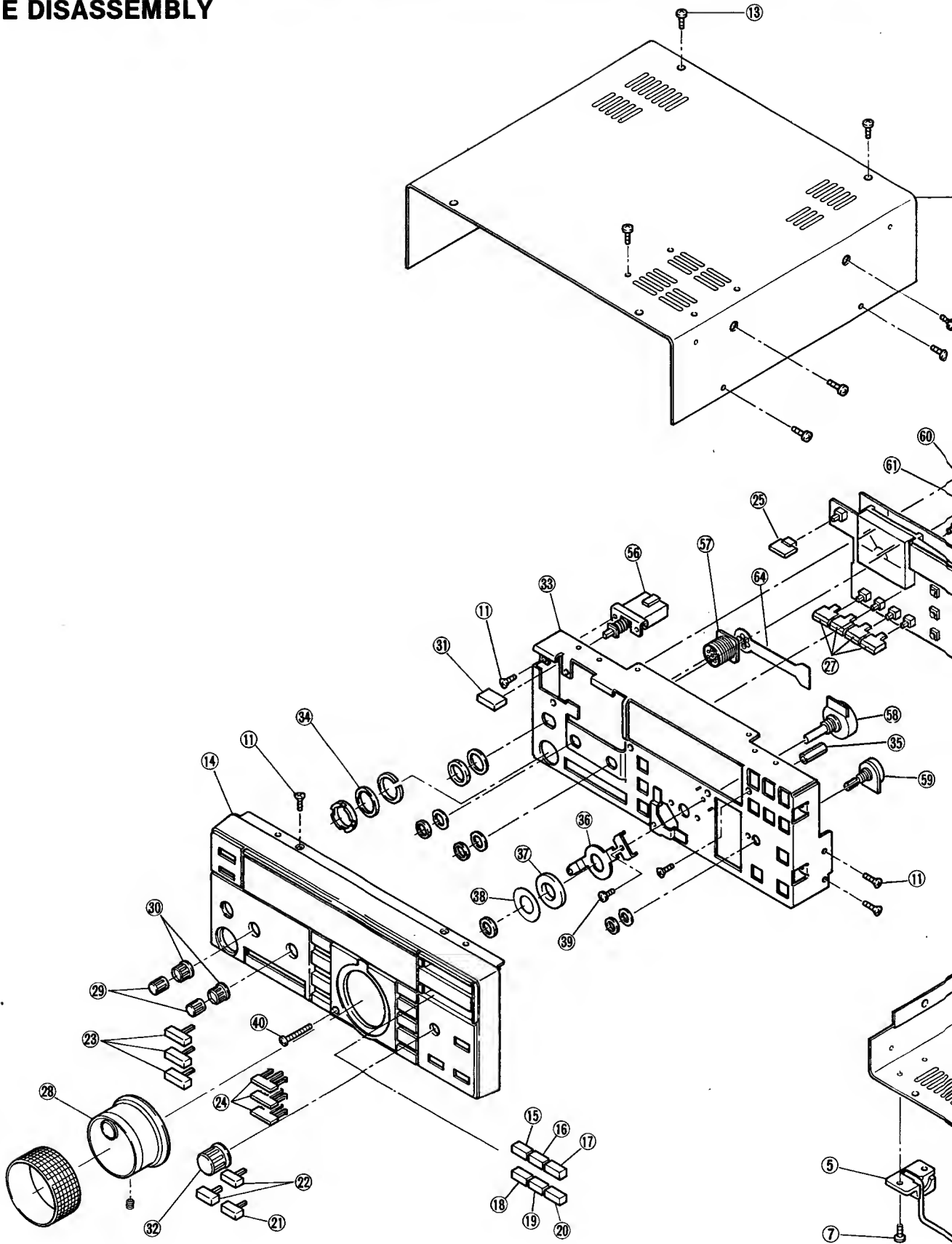

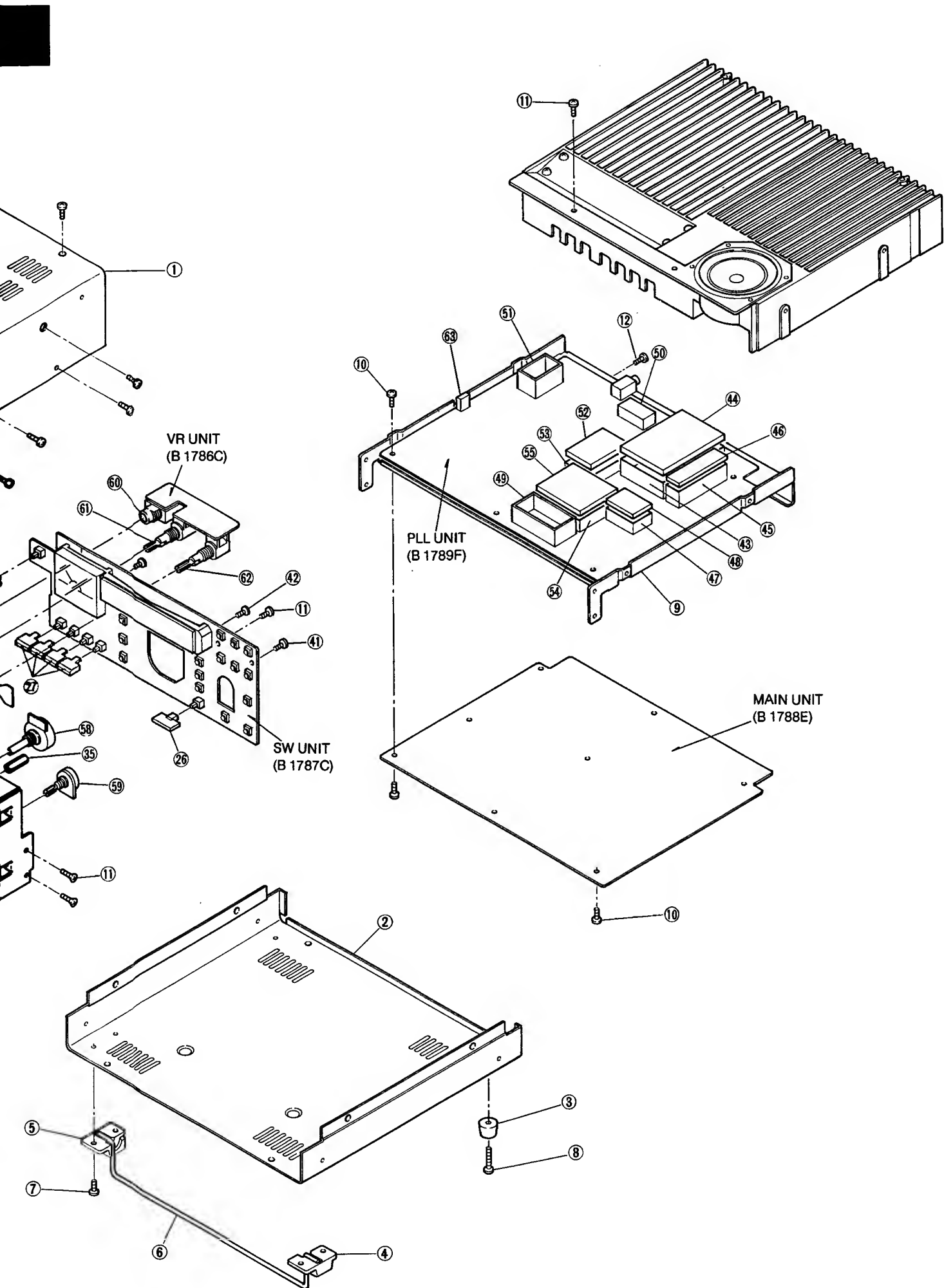

• FRAME DISASSEMBLY

LABEL NUMBER	ORDER NO.	DESCRIPTION	QTY.	LABEL NUMBER	ORDER NO.	DESCRIPTION	QTY.
①	8110003270	Top cover	1	③⑤	8930000720	Thread spacer (V)	4
②	8110003280	Bottom cover	1	③⑥	8930013990	610 Brake plate	1
③	8930002900	Rubber foot (A)	2	③⑦	8930014030	610 Brake pat	1
④	8930005790	Foot (A)	1	③⑧	8930013940	610 Brake sheet	1
⑤	8930005800	Foot (B)	1	③⑨	8810001110	PH B0 M3 × 6	1
⑥	8010001520	Stand (C)	1	④⑩	8810005470	PH M2.6 × 14 ZK	1
⑦	8810005520	PH B1 M3 × 8 ZK	4	④①	8810001650	PH FT M3 × 6	9
⑧	8810005540	PH B1 M4 × 10	2	④②	8810001320	PH B1 M2.6 × 6 Ni	4
⑨	8010007851	610 Chassis-1	1	④③	8510001330	79 shield case	1
⑩	8810001350	PH B1 M3 × 6	16	④④	8510001340	79 shield case cover	1
⑪	8810002160	FH M3 × 5	16	④⑤	8510001060	Shield case	1
⑫	8810003670	ICOM screw A 6	2	④⑥	8510001740	Shield case cover	1
⑬	8810005510	FH M3 × 6 ZK BS	16	④⑦	8510000881	194 VCO case-1	1
⑭	8210004670	610 Front panel (B)	1	④⑧	8510003460	194 VCO case cover (A)	1
⑮	8610004640	Button K119 [VFO]	1	④⑨	8510000230	220 shield case	1
⑯	8610004650	Button K119 (A) [SPLIT]	1	⑤⑩	8510002200	VCO case	1
⑰	8610004660	Button K119 (B) [UP]	1	⑤①	8510000881	194 VCO case-1	1
⑱	8610004670	Button K119 (C) [MEMO]	1	⑤②	8510002690	PA shield case (B)	1
⑲	8610004680	Button K119 (D) [MW]	1	⑤③	8510004360	PA shield case (B) cover (A)	1
⑳	8610004690	Button K119 (E) [DOWN]	1	⑤④	8510005310	DDS shield case	1
㉑	8610004700	Button K119 (F) [FUNC]	1	⑤⑤	8510005320	DDS shield case cover	1
㉒	8610004710	Button K119 (G) [RIT, TUNER]	2	⑤⑥	2230000120	Switch [POWER] SDDSA3159A	1
㉓	8610004720	Button K120 [SSB, CW/N, AM/FM]	3	⑤⑦	6510000190	Connector [MIC] FM214-8SS (P)	1
㉔	8610004730	Button K121 [kHz, MHz, BAND]	3	⑤⑧	7600000100	Rotary encoder EC24B50B0013A	1
㉕	8610003850	Button K98 [TRANSMIT]	1	⑤⑨	7210000570	Variable resistor [RIT]	1
㉖	8610004741	Button K122-1 [LOCK]	1	⑥⑩	6450000810	Connector [PHONES] HLJ4306-01-3070	1
㉗	8610004751	Button K123-1 [NB, ATT, PRE, AGC]	4				
㉘	8610004760	Dial N104 (A) (incl. rubber ring and screw)	1	⑥①	7210001320	Variable resistor [AF/SQL] RK124221002DA	1
㉙	8610004770	Knob N45C [AF, MIC]	2	⑥②	7210001550	Variable resistor [MIC/RF PWR] RK1242210032A	1
㉚	8610000500	Knob N69 [SQL, RF PWR]	2				
㉛	8610001560	Button K42 [POWER]	1	⑥③	7210001530	Variable resistor [RIT] RK09K1110AEGA	1
㉜	8610004780	Knob N87 (B) [RIT]	1				
㉝	8010007860	610 Sub chassis	1	⑥④	0910006330	Flexible cable P.C. Board B 792	1
㉞	8930003200	Spacer (P)	1				

Screw abbreviations PH: Pan head FH: Flat head B0, B1, FT: Self-tapping screw ZK: Black Ni: Nickel
BS: Brass

5-2 PA UNIT AND ACCESSORIES

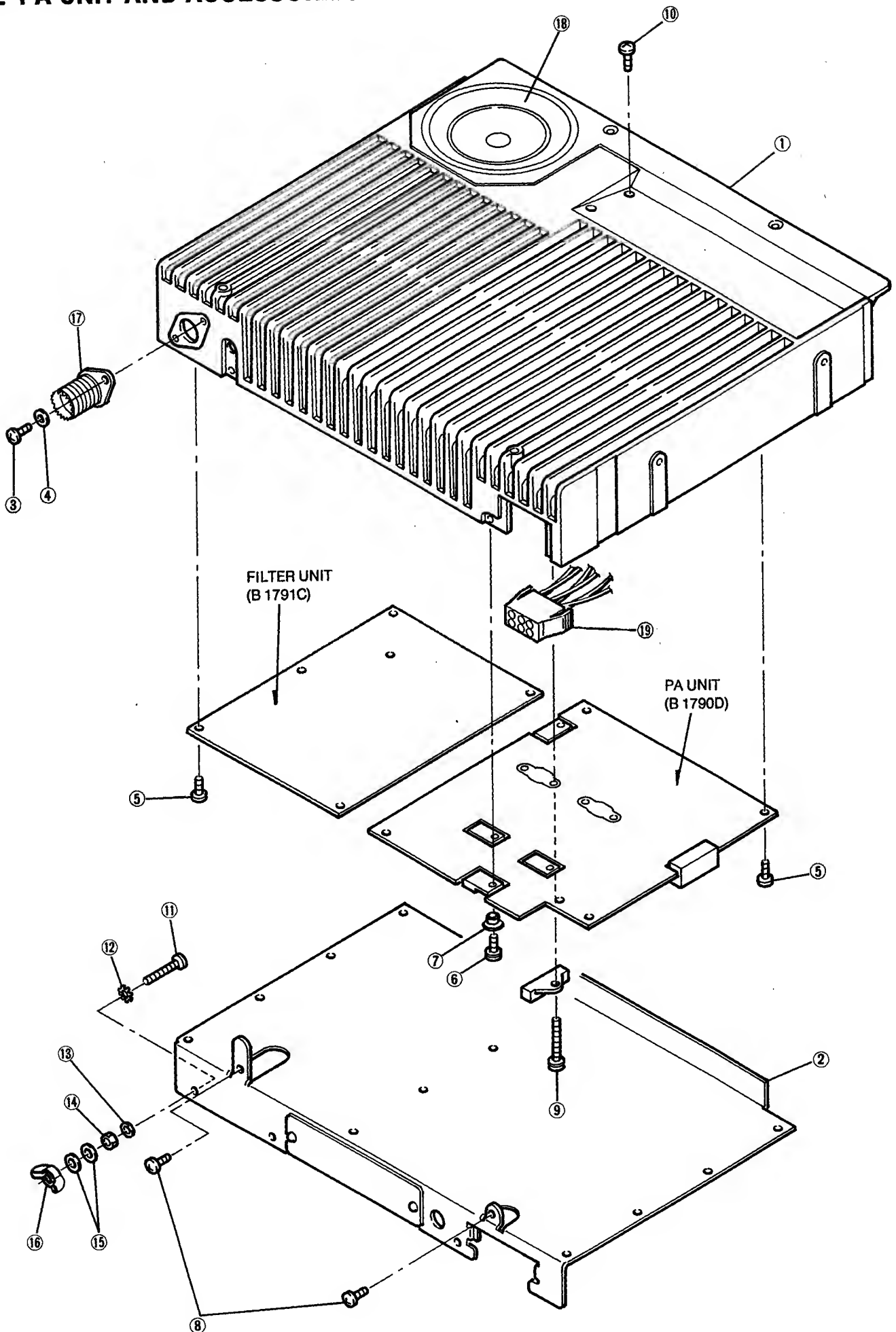

• PA UNIT

LABEL NUMBER	ORDER NO.	DESCRIPTION	QTY.
①	8410000781	401 Heatsink-1	1
②	8510005462	PA cover-2	1
③	8810001910	PH M3×6 Ni BS	2
④	8850000420	Spring washer M3 Ni	2
⑤	8810001350	PH B1 M3×6	24
⑥	8810003170	Set screw A M3×8	7
⑦	6910000310	Bushing B312D	1
⑧	8810003670	ICOM screw A6	2
⑨	8810003210	Set screw A M3×15	1
⑩	8810000220	PH M3×5	4
⑪	8810001980	PH M5×16 Ni BS	1
⑫	8850000590	Star washer M5	1
⑬	8850000440	Spring washer M5 Ni	1
⑭	8830000210	Nut M5 Ni BS	1
⑮	8850000150	Flat washer M5 Ni BS	2
⑯	8830000360	Wing nut M5 Ni	1
⑰	6510004880	ANT connector MR-DS-E 01	1
⑱	2510000040	Speaker C065K1210810	1
⑲	6510003780	DC power socket LLR-6	1

Screw abbreviations PH: Pan head B1: Self-tapping screw Ni: Nickel BS: Brass

• ACCESSORIES

LABEL NUMBER	ORDER NO.	DESCRIPTION	QTY.
①	Optional product	DC power cable OPC-025 A	1
②	Optional product	Hand microphone HM-12	1
③	5210000080	Spare fuse FGB 20A	1
④	5210000130	Spare fuse FGB 4A	1
⑤	8810005500	FH B1 M4×12 CR	2
⑥	8810001600	PH ST M3×6	4

Screw abbreviations PH: Pan head FH: Flat head B1, ST: Self-tapping screw

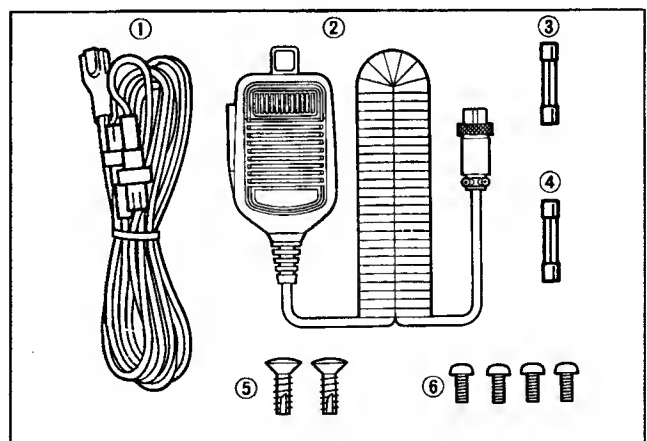

5-3 FRONT AND PLL UNITS CONNECTOR ASSEMBLY

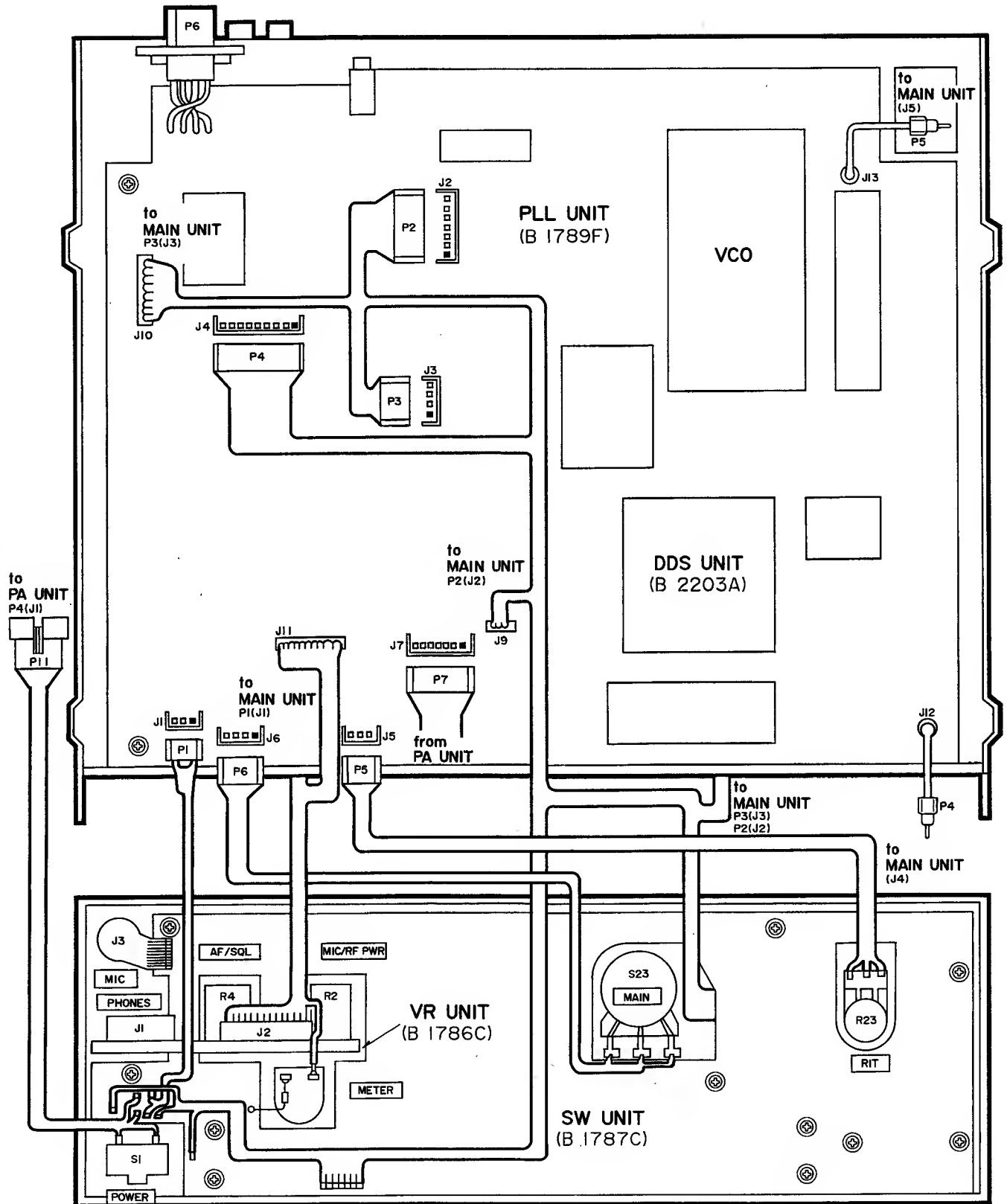

5-4 FRONT AND MAIN UNITS CONNECTOR ASSEMBLY

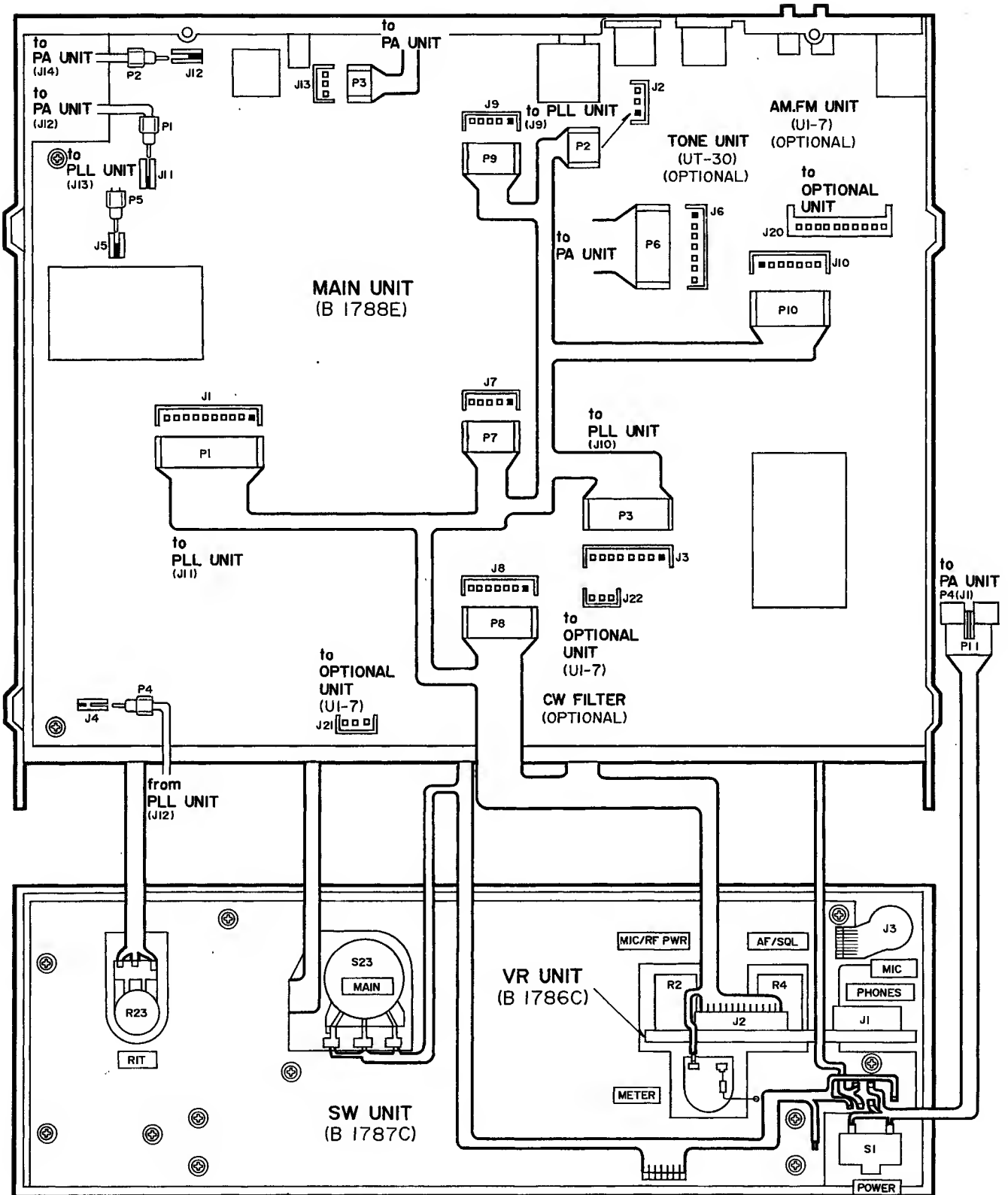

5-5 PA AND FILTER UNITS CONNECTOR ASSEMBLY

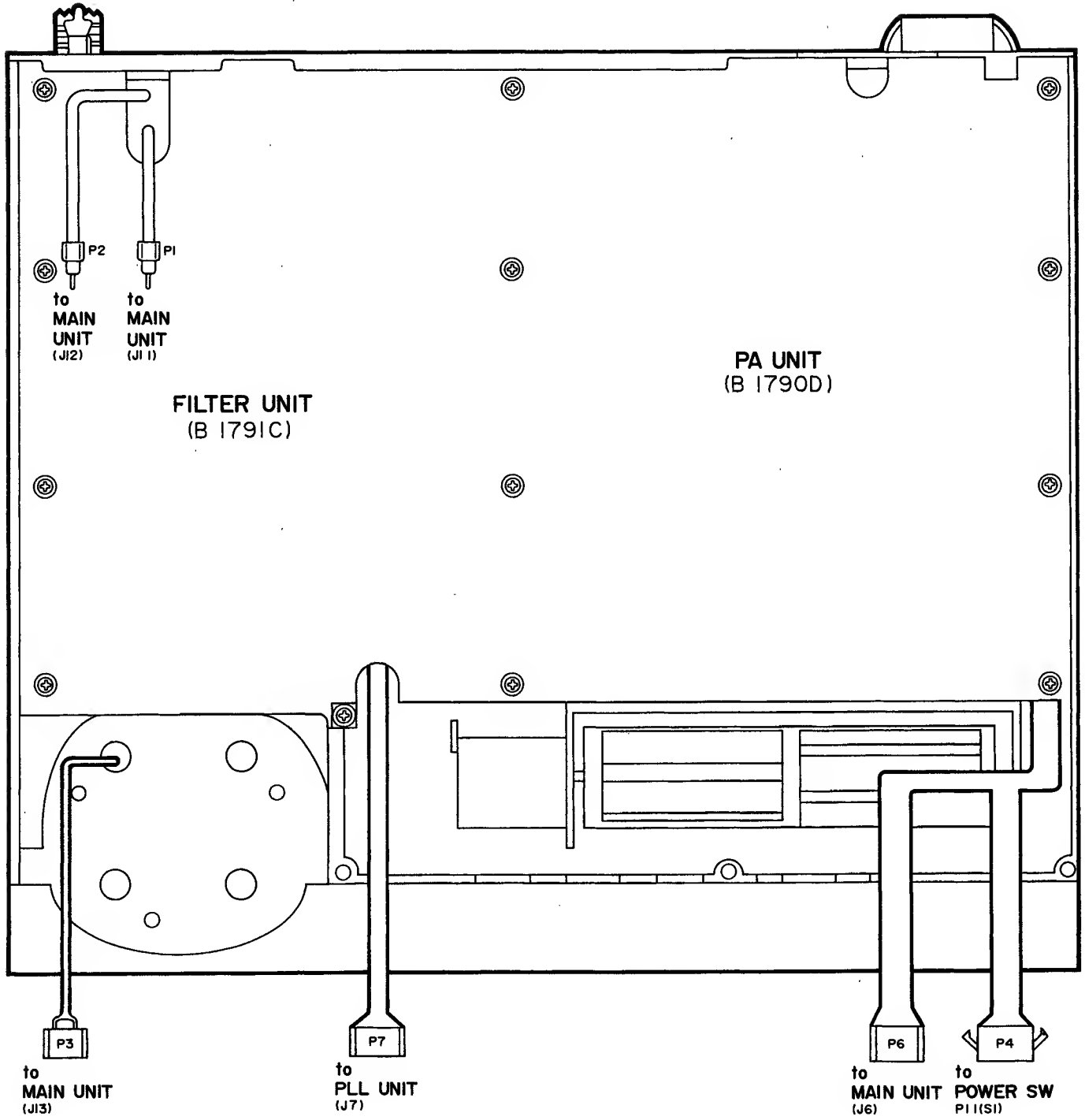

SECTION 6 ADJUSTMENT PROCEDURES

6-1 PREPARATION BEFORE SERVICING

REQUIRED TEST EQUIPMENT

EQUIPMENT	GRADE AND RANGE	EQUIPMENT	GRADE AND RANGE
AC power supply	Output voltage : 13.8 V DC Current capacity : 30 A or more	DC voltmeter	Input impedance : 50 k Ω /DC or better
RF power meter (terminated type)	Measuring range : 10~200 W Frequency range : 1.8~30 MHz Impedance : 50 Ω SWR : Less than 1.2 : 1	AC milli-voltmeter	Measuring range : 10 mV~10 V
Frequency counter	Frequency range : 0.1~100 MHz Frequency accuracy : ± 1 ppm or better Sensitivity : 100 mV or better	External speaker	Impedance : 8 Ω
RF voltmeter	Frequency range : 0.1~100 MHz Measuring range : 0.01~10 V	Ammeter	Measurement capability: 1 A and 30 A
Oscilloscope	Frequency range : DC~20 MHz Measuring range : 0.01~10 V	Audio generator	Frequency range : 300~3000 Hz Output level : 1~500 mV
Standard signal generator (SSG)	Frequency range : 0.1~30 MHz Output level : -127~-17 dBm (0.1 μ V~32 mV)	Attenuator	Power attenuation : 40 or 50 dB Capacity : 150 W or more
		Spectrum analyzer	Frequency minimum : At least 90 MHz Spectrum bandwidth : ± 100 kHz or more

CONNECTION

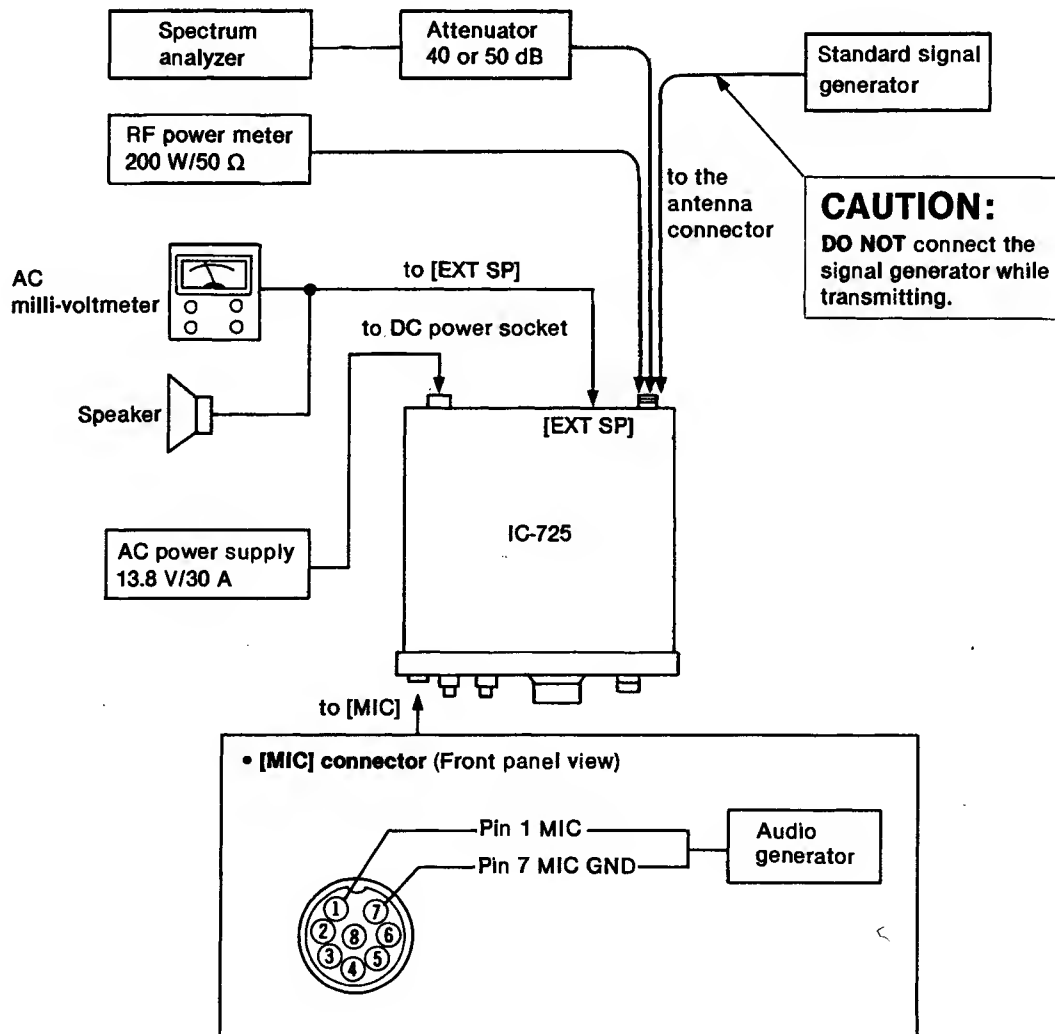

6-2 PLL ADJUSTMENT

ADJUSTMENT		ADJUSTMENT CONDITIONS	MEASUREMENT		VALUE	ADJUSTMENT POINT	
			UNIT	LOCATION		UNIT	ADJUST
REFERENCE FREQUENCY	1	<ul style="list-style-type: none"> • Displayed frequency: 14.10000 MHz • Mode : USB • Receiving 	PLL	Terminate P4 to ground with a 50 Ω resistor. Connect the RF voltmeter to P4.	Pre-set to center.	PLL	C134
	2						Maximum level (More than +3 dBm)
	3				61.4400 MHz		L35
	4	After adjustment, remove the resistor from P4 and re-plug P4.					
DDS CLOCK	1	<ul style="list-style-type: none"> • Displayed frequency: 14.10000 MHz • Mode : USB • Receiving 	DDS	Connect the frequency counter to IC4 pin 11 or IC5 pin 11.	5.24288 MHz	DDS	C1
DDS LOOP	1	<ul style="list-style-type: none"> • Displayed frequency: 14.12650 MHz • Mode : AM • Receiving 	PLL	Connect the oscilloscope to R133 (rear panel side).	1.0 V DC	PLL	L30
	2	<ul style="list-style-type: none"> • Displayed frequency: 14.12649 MHz 			Approx. 2.0 V DC		Verify
1ST LO LOCK VOLTAGE	1	<ul style="list-style-type: none"> • Displayed frequency: 7.99999 MHz • Mode : USB • Receiving 	PLL	Connect the oscilloscope to R77. (shielding case side)	6.5 V DC	PLL	C35
	2	<ul style="list-style-type: none"> • Displayed frequency: 14.99999 MHz 			6.5 V DC		C46
	3	<ul style="list-style-type: none"> • Displayed frequency: 21.99999 MHz 			6.5 V DC		C59
	4	<ul style="list-style-type: none"> • Displayed frequency: 33.00000 MHz 			7.5 V DC		C70
	5	<ul style="list-style-type: none"> • Displayed frequencies: 0.50000 MHz, 8.00000 MHz, 15.00000 MHz and 22.00000 MHz 			More than 2.0 V DC		Verify
1ST LO OUTPUT LEVEL	1	<ul style="list-style-type: none"> • Displayed frequency: 14.10000 MHz • Mode : USB • Receiving 	PLL	Terminate P5 to ground with a 50 Ω resistor. Connect the RF voltmeter to P5.	More than 0 dBm		Verify
	2	After adjustment, remove the resistor from P5 and re-plug P5.					
RIT	1	<ul style="list-style-type: none"> • Displayed frequency: 14.10000 MHz • Mode : USB • Set the signal generator; Level : 50 μV (-73 dBm) • Modulation: OFF • [RIT] switch : ON and OFF • Receiving 	Top cover	Speaker	Pre-set to center.	Front panel	[RIT] control
	2				Same tone pitch on both conditions.		PLL

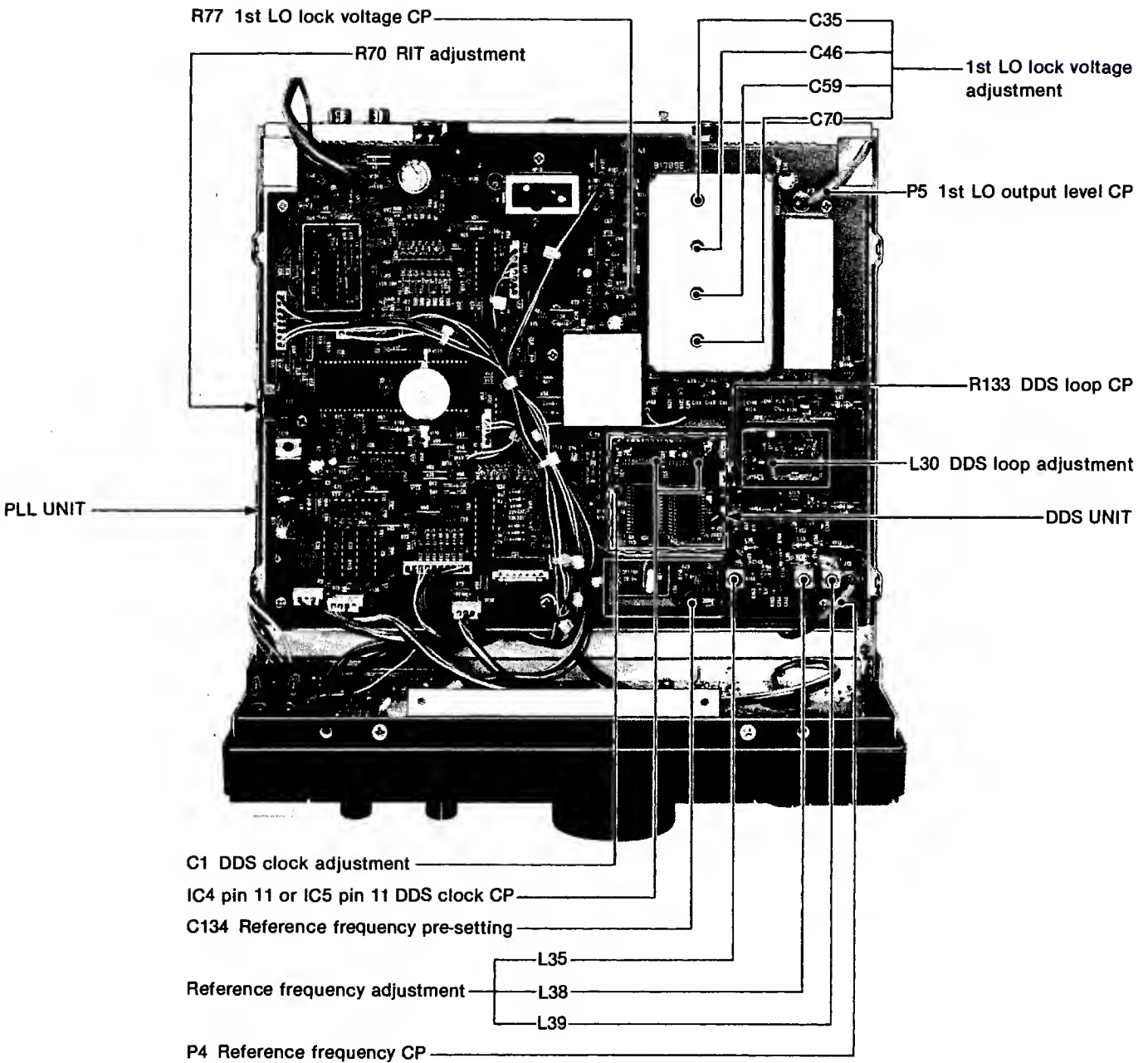

6-3 RECEIVER ADJUSTMENT

ADJUSTMENT	ADJUSTMENT CONDITIONS	MEASUREMENT		VALUE	ADJUSTMENT POINT			
		UNIT	LOCATION		UNIT	ADJUST		
BFO FREQUENCY	1	<ul style="list-style-type: none"> Displayed frequency: 14.10000 MHz Mode : USB Receiving 	MAIN	Connect the frequency counter to R266.	9.01300 MHz	MAIN	C294	
	2	<ul style="list-style-type: none"> Mode : CW Transmitting 					9.01060 MHz	L83
	3	<ul style="list-style-type: none"> Mode : LSB Receiving 					9.01000 MHz	L82
	4	<ul style="list-style-type: none"> Mode : CW 					9.00980 MHz (± 150 Hz)	Verify
	5	<ul style="list-style-type: none"> Mode : AM 					No output	
SENSITIVITY	1	<ul style="list-style-type: none"> Displayed frequency: 14.10000 MHz Mode : USB [RIT] switch : OFF [AGC] switch : IN (Fast) [ATT] switch : OFF [NB] switch : OFF [PRE] switch : ON [SQL] control : Max. CCW Set the signal generator; Level : 0.16 μV (−123 dBm) Modulation: OFF Receiving 	Rear panel	Connect the AC millivoltmeter to the [EXT SP] jack with an 8 Ω load.	Pre-set to max. CW.	MAIN	R138	
					Maximum audio output level		L33, L34, L35, L36, L16, L17, L21, L22, L23, L79, L78, L77	
TOTAL GAIN	1	<ul style="list-style-type: none"> Displayed frequency: 14.10000 MHz Mode : USB [PRE] switch : OFF Set the signal generator; Level : 1.0 mV (−47 dBm) Modulation: OFF Receiving 	Rear panel	Connect the AC millivoltmeter to the [EXT SP] jack with an 8 Ω load.	1.0 V (0 dB)	Front panel	[AF] control	
	2	<ul style="list-style-type: none"> Set the signal generator; Level : OFF 			30 mV (−30 dB)		MAIN	R138
S-METER	1	<ul style="list-style-type: none"> Displayed frequency: 14.10000 MHz Mode : USB [PRE] switch : OFF Set the signal generator; Level : 50 μV (−73 dBm) Modulation: OFF Receiving 	Front panel	Meter	S9	MAIN	R116	
	2	<ul style="list-style-type: none"> Set the signal generator; Level : 50 mV (−13 dBm) 			S9+60 dB		R110	
	3	Repeat above adjustments 1 and 2 a couple of times.						

RECEIVER ADJUSTMENT (CONTINUED)

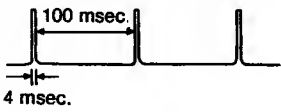
ADJUSTMENT	ADJUSTMENT CONDITIONS	MEASUREMENT		VALUE	ADJUSTMENT POINT	
		UNIT	LOCATION		UNIT	ADJUST
NOISE BLANKER	1 <ul style="list-style-type: none"> • Displayed frequency: 14.10000 MHz • Mode : USB • [NB] switch : ON • Apply an RF signal including the following pulse noise to the antenna connector. RF signal level : 3.2 μV (-97 dBm) • Receiving 	MAIN	Connect the oscilloscope to the cathode of D13.	Adjust for maximum waveform on the oscilloscope.	MAIN	L25, L26

MAIN UNIT

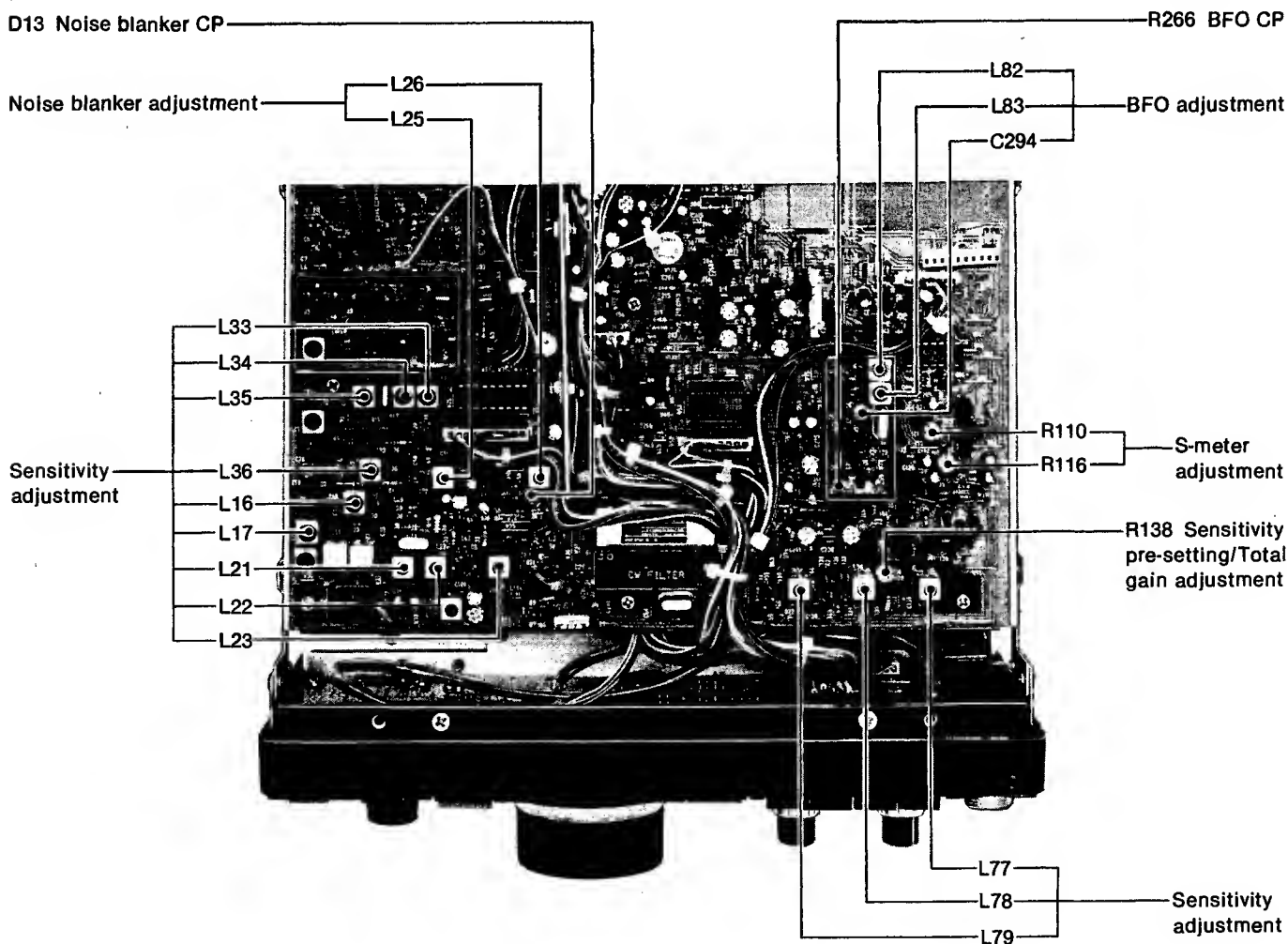

6-4 TRANSMITTER ADJUSTMENT

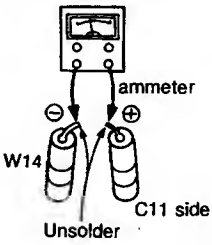
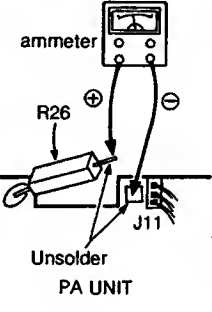
ADJUSTMENT	ADJUSTMENT CONDITIONS	MEASUREMENT		VALUE	ADJUSTMENT POINT	
		UNIT	LOCATION		UNIT	ADJUST
IDLING CURRENT Ⓐ For drive transistors	1 • Displayed frequency: 14.10000 MHz • Mode : CW • [TRANSMIT] switch: IN • [KEY] jack : No connection	PA	Unsolder W14 and connect the ammeter to the unsoldering points. 	50 mA	PA	R8
		PA	Unsolder R26 and connect the ammeter to the unsoldering points. 	300 mA	PA	R19
Ⓑ For final transistors	2	After adjustment, re-solder W14 and R26.				

PA AND FILTER UNITS

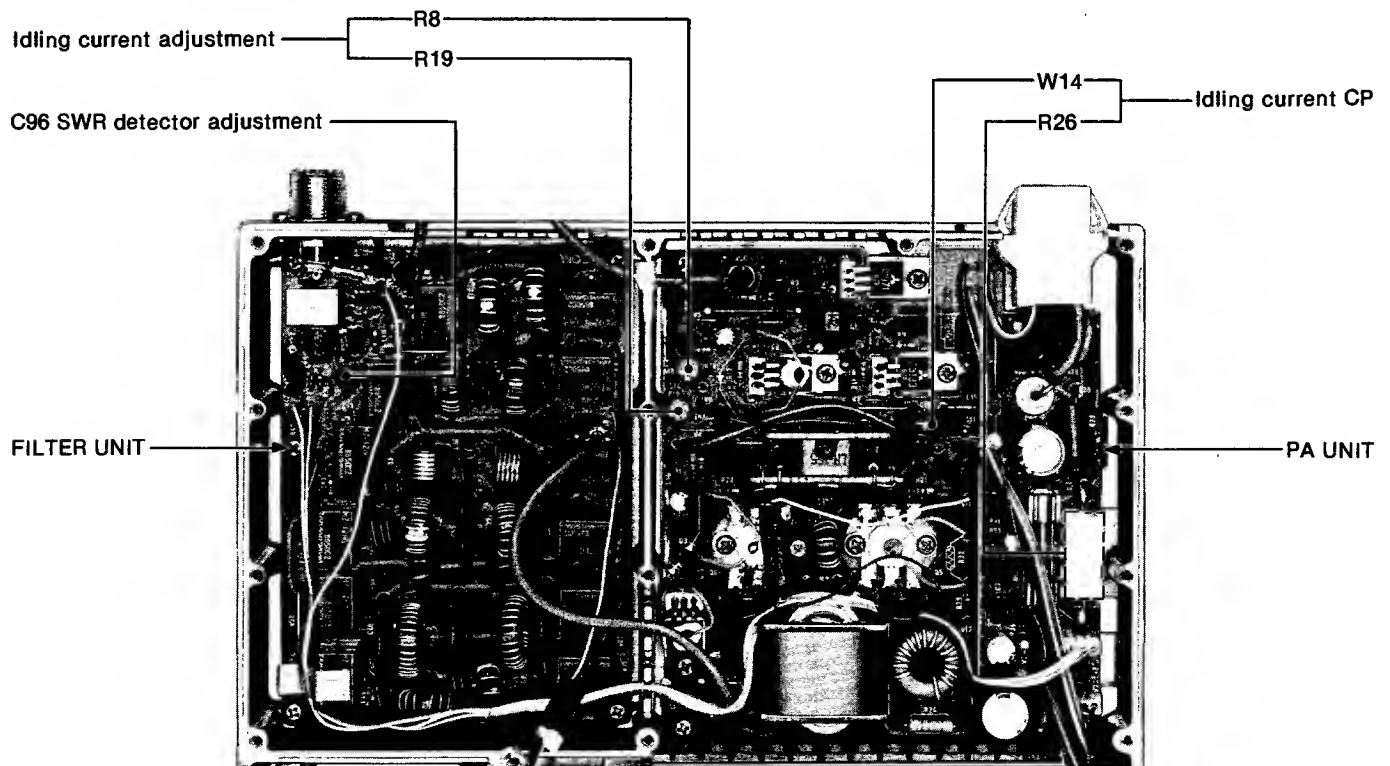

TRANSMITTER ADJUSTMENT (CONTINUED)

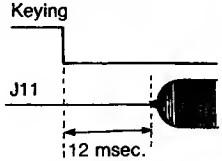
ADJUSTMENT	ADJUSTMENT CONDITIONS	MEASUREMENT		VALUE	ADJUSTMENT POINT		
		UNIT	LOCATION		UNIT	ADJUST	
SWR DETECTOR	1	<ul style="list-style-type: none"> • Displayed frequency: 14.10000 MHz • Mode : USB • [RF PWR] control : Max. CW 	Rear panel	Connect the RF power meter to the antenna connector.	100 W	Front panel	[MIC] control
	2	<ul style="list-style-type: none"> • Connect a jumper wire between R87 front side and ground. • Apply an RF signal to the [MIC] connector. Level : 10 mV/1.5 kHz • Transmitting 	MAIN	Connect the DC voltmeter to J6 pin 2.	Minimum	FILTER	C96 (See p. 6-6)
	3	After adjustment, remove the jumper wire from R87.					
TRANSMIT GAIN	1	<ul style="list-style-type: none"> • Displayed frequency: 14.10000 MHz • Mode : USB • [RF PWR] control : Max. CW • Apply an AF signal to the [MIC] connector. Level : 1 mV/1.5 kHz • Transmitting 	Rear panel	Connect the RF power meter to the antenna connector.	Pre-set to max. CCW.	MAIN	R85
					50 W	Front panel	[MIC] control
					Maximum level	MAIN	L37, L17, L16, L14, L7
	2	<ul style="list-style-type: none"> • [MIC] control : Max. CW 		50 W		R85	
NOTE: Adjust the [MIC] control to keep the output power at 50 W for each adjustment.							
OUTPUT POWER	1	<ul style="list-style-type: none"> • Displayed frequency: 1.91000 MHz • Mode : CW • [RF PWR] control : Max. CW 	Rear panel	Connect the RF power meter to the antenna connector.	Pre-set to max. CCW.	MAIN	R194, R241
	2	<ul style="list-style-type: none"> • Connect a key to the [KEY] jack and keep the key down. 			100 W		R210
	3	<ul style="list-style-type: none"> • [RF PWR] control : Max. CCW 			10 W		R208
	4	Repeat steps 2 and 3 a couple of times.					
Ic APC	1	<ul style="list-style-type: none"> • Displayed frequency: 14.10000 MHz • Mode : CW • [RF PWR] control : Max. CW • Connect a jumper wire between J6 pin 3 and ground. • Connect a key to the [KEY] jack and keep the key down. 	Rear panel	Connect the ammeter between the AC power supply and IC-725.	22 A	MAIN	R194
	2	After adjustment, remove the jumper wire from J6 pin 3.					
Po METER	1	<ul style="list-style-type: none"> • Displayed frequency: 14.10000 MHz • Mode : CW • [RF PWR] control : Max. CW • Connect a key to the [KEY] jack and keep the key down. 	Front panel	Meter	100 % (full scale)	MAIN	R186
CW DELAY TIME	1	<ul style="list-style-type: none"> • Displayed frequency: 14.10000 MHz • Mode : CW • [BK IN] switch : ON • [DELAY] control : Max. CCW • Connect an external electronic keyer to the [KEY] jack and close the key. 	MAIN	Connect the oscilloscope to J11 and the electronic keyer.	Adjust as follows: Keying 	MAIN	R241

TRANSMITTER ADJUSTMENT (CONTINUED)

ADJUSTMENT	ADJUSTMENT CONDITIONS	MEASUREMENT		VALUE	ADJUSTMENT POINT	
		UNIT	LOCATION		UNIT	ADJUST
CARRIER SUPPRESSION	1 <ul style="list-style-type: none"> • Displayed frequency: 1.91000 MHz • Mode : USB and LSB • [MIC] control : Max. CCW • Apply no signal to the [MIC] connector. • Transmitting 	Rear panel	Connect the spectrum analyzer to the antenna connector via the attenuator.	Minimum carrier level (Less than -50 dB)	MAIN	R177, R179 (Alternately adjust)

MAIN UNIT

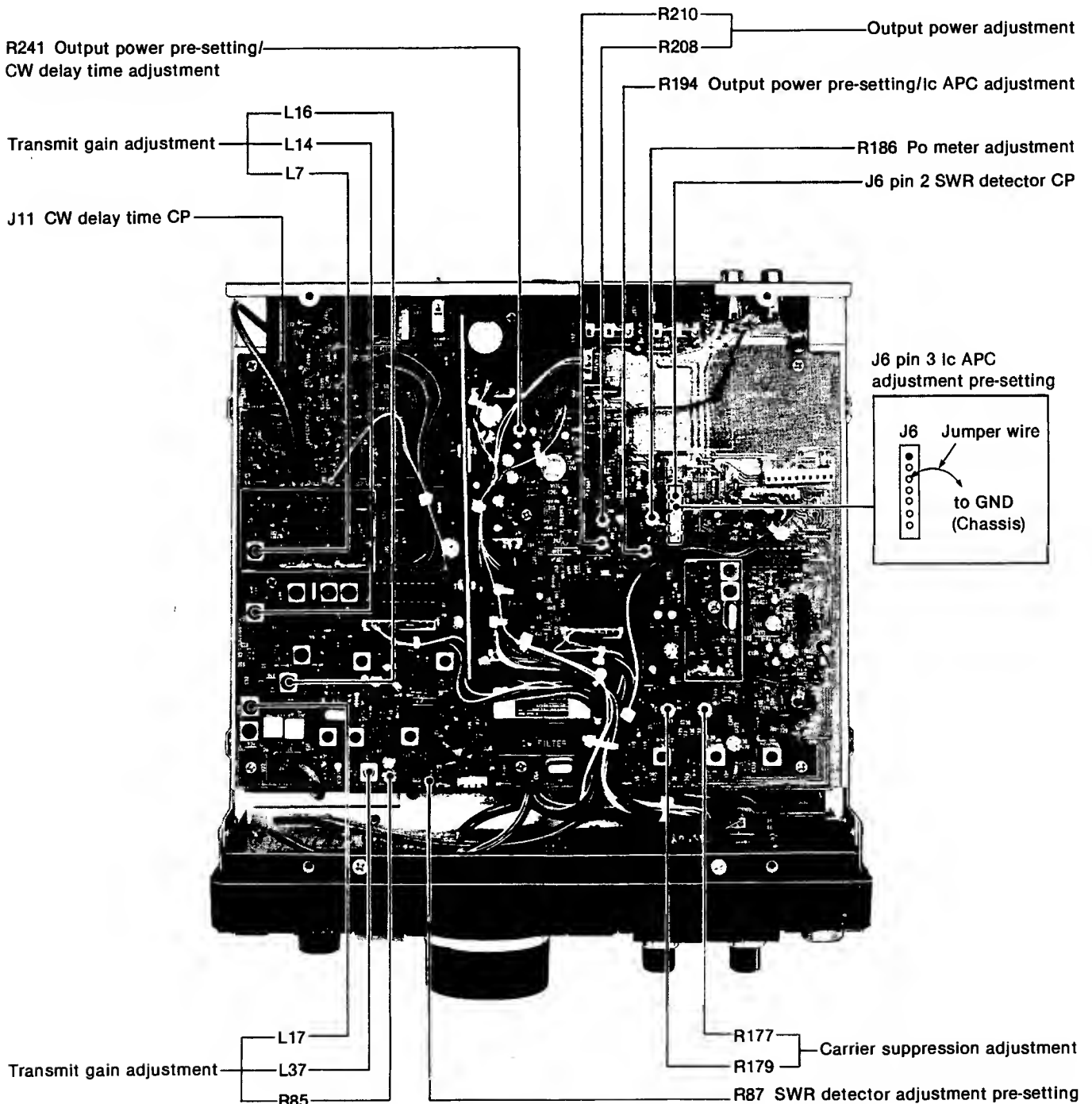

SECTION 7 BOARD LAYOUTS

7-1 FRONT UNIT

• SW UNIT

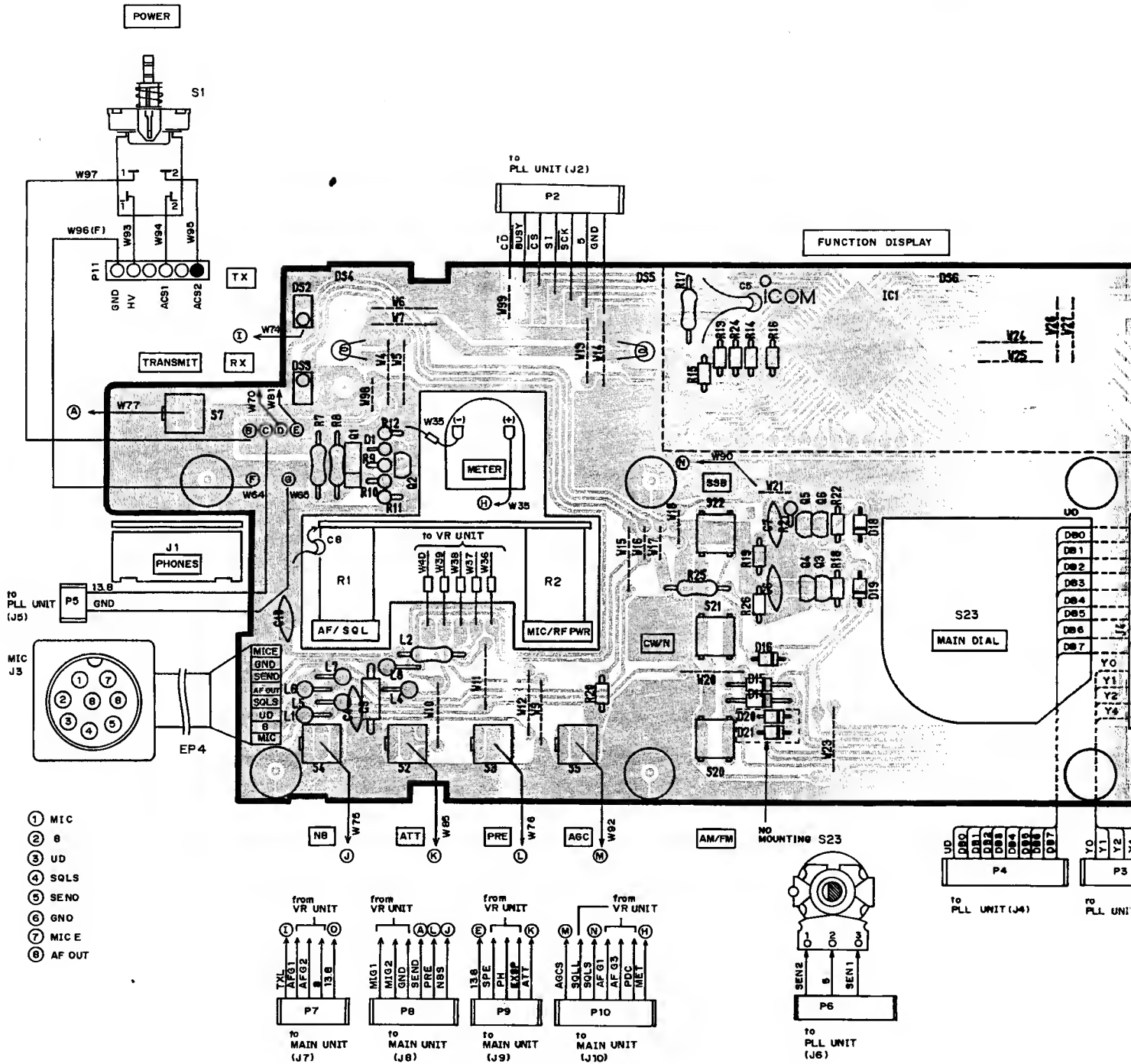

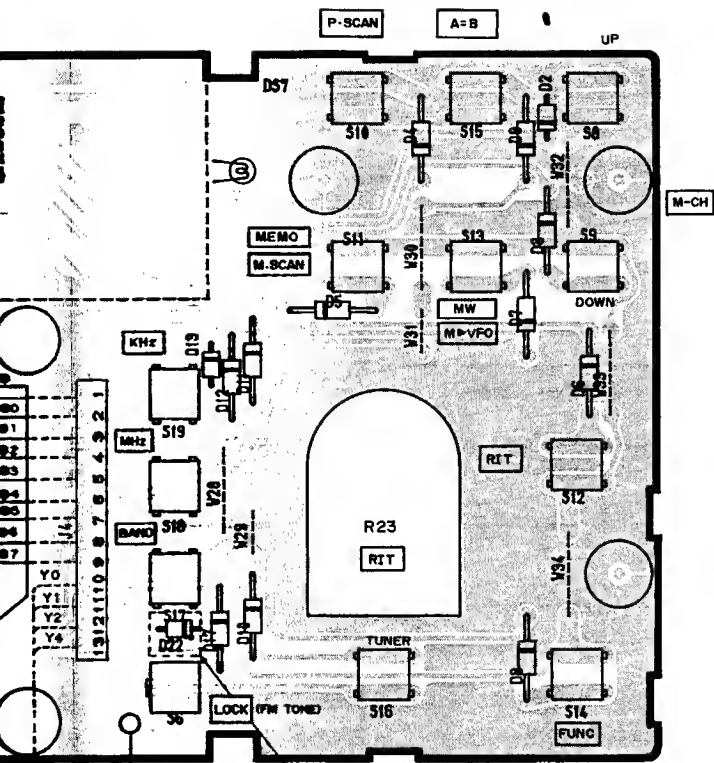

2SB909M Q
Q1.

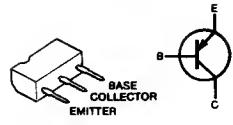

2SC2458 GR
Q2, Q3, Q4, Q6

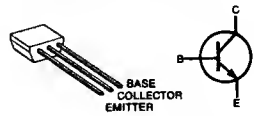

RN1204
Q5

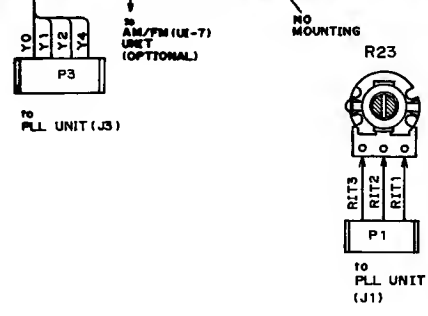
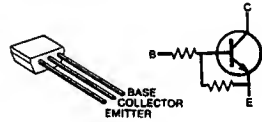

• VR UNIT

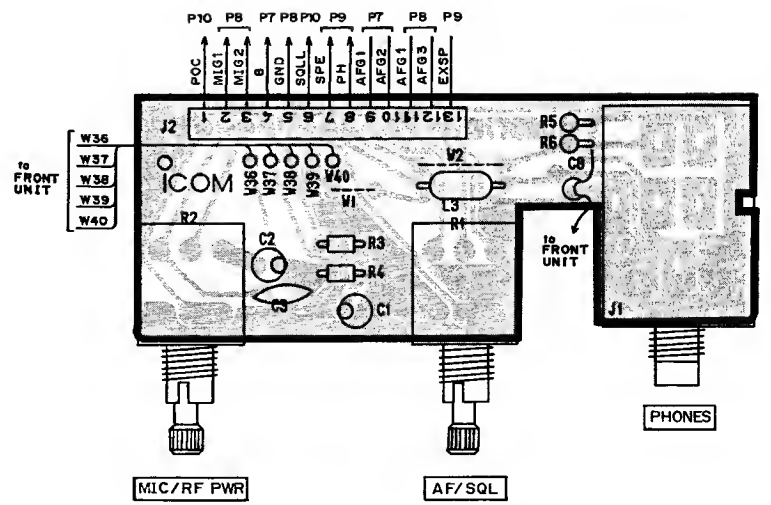

7-2 MAIN UNIT

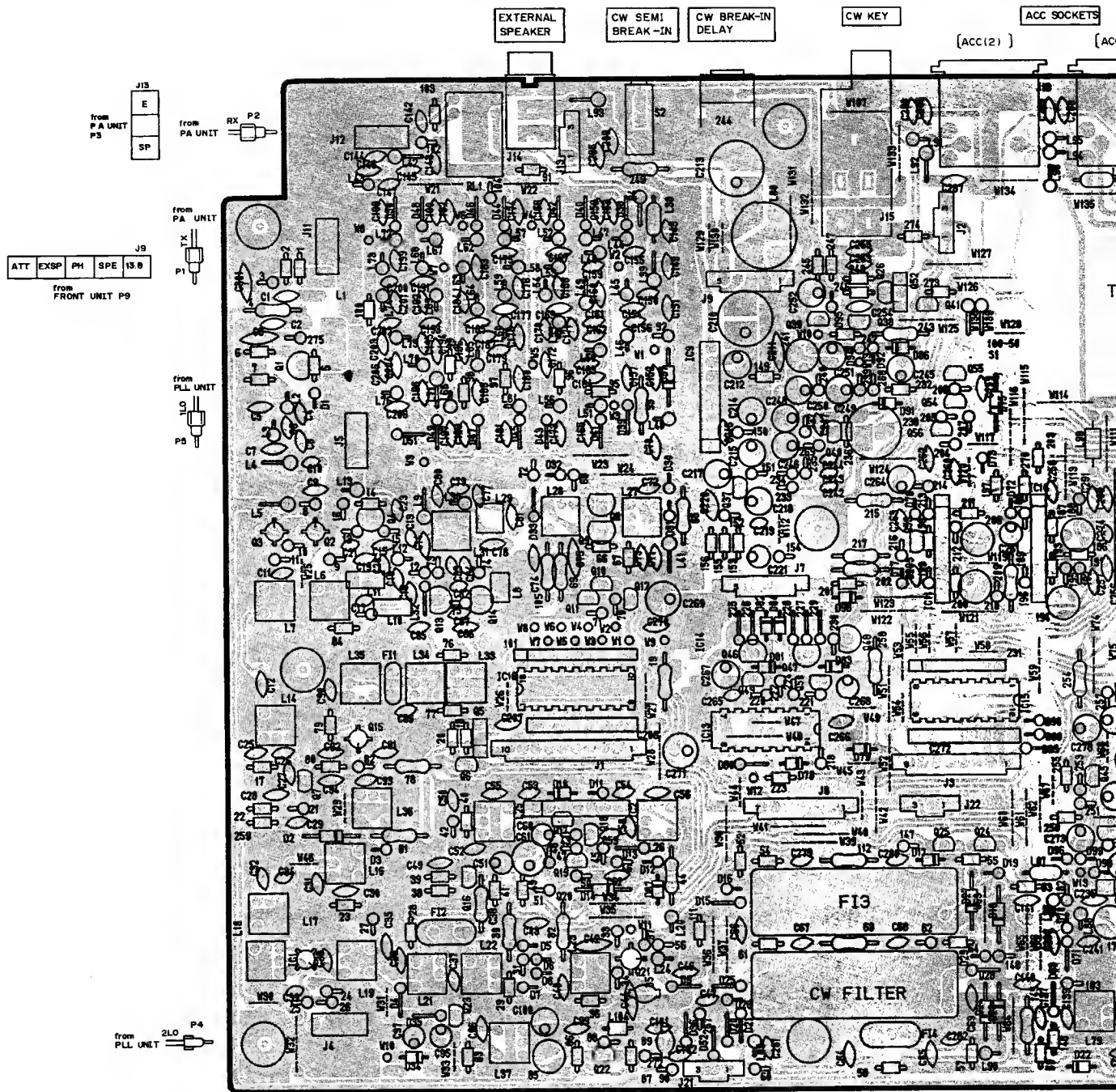

2SA1048 GR
Q17, Q38, Q53

2SB909M Q
Q5

2SC2053
Q1, Q4

2SC2458 GR
Q11, Q18, Q19, Q26, Q29, Q31, Q35, Q36, Q37, Q40, Q44, Q45, Q49, Q50, Q56

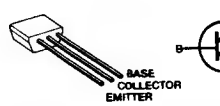
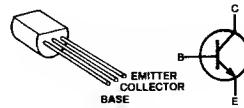
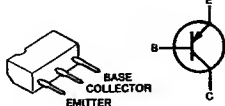
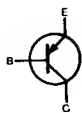
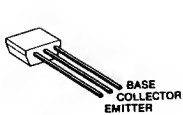

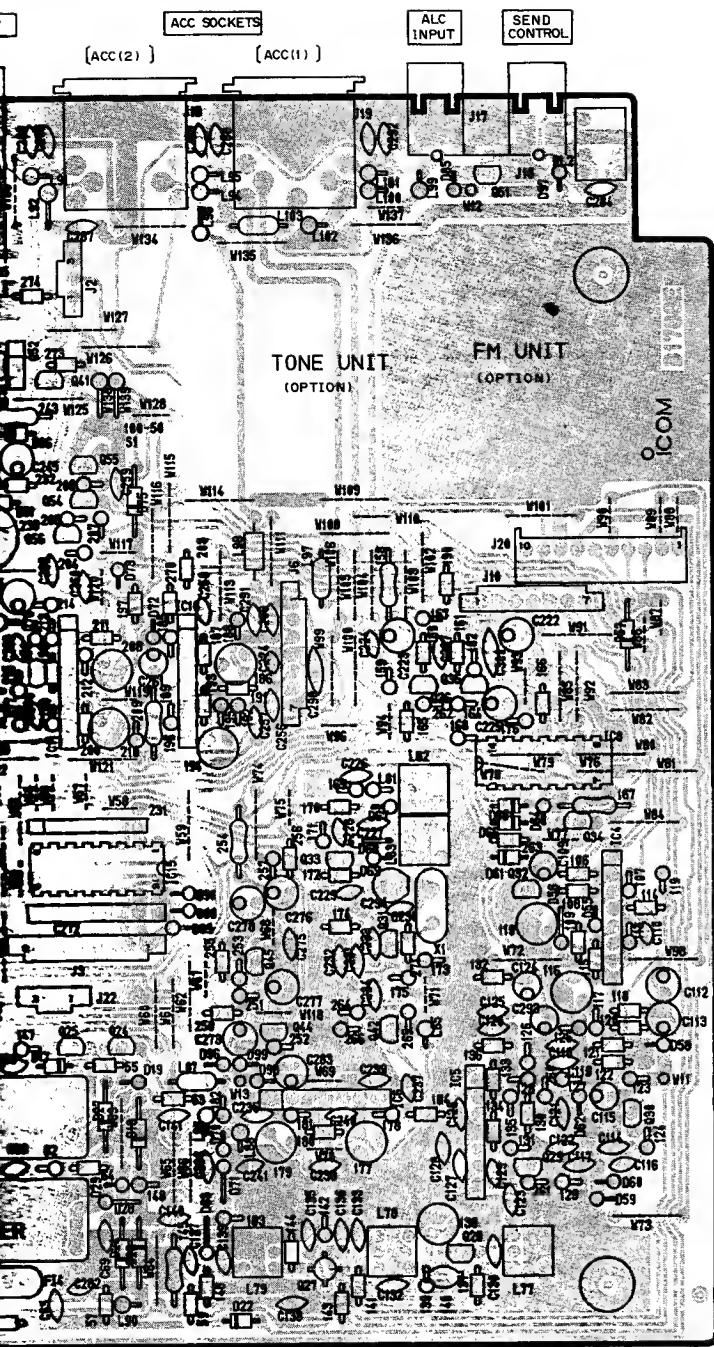

J2

BAND
-5
2BN

from PLL UNIT P2(J9)

J20

from AM FM UNIT(U1-7) J1 (OPTIONAL)								
AMLC	GND	AF	F5M	T8	AM8	FM8	RB	B

J10

MET	POC	AF5	AF6	SOL5	SOL6	AGCS
-----	-----	-----	-----	------	------	------

J6

from FRONT UNIT (P10)

13.B
REF
FOR
GNP
ICL
ICM
PAT8

from P A UNIT P6

J3

TUNK	B	FM	NAR	AM	LSB	CW	USB
------	---	----	-----	----	-----	----	-----

from PLL UNIT P5(J10)

J22

FM12	FM1
------	-----

from FM/AM UNIT (U6-7) P2 (OPTIONAL)

2SC2458 GR
Q11, Q18, Q19, Q26, Q29, Q30, Q31, Q35, Q36, Q37, Q40, Q42, Q44, Q45, Q49, Q50, Q56

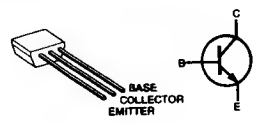

2SD1225M R
Q52

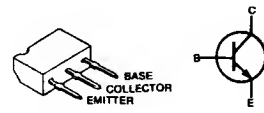

2SD468C
Q46, Q47, Q48

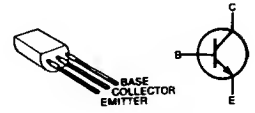

2SK125
Q13, Q14, Q8, Q9

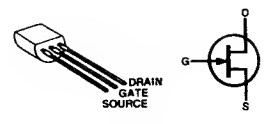

2SK192A-Y
Q16

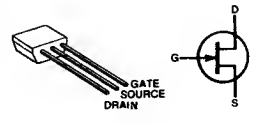

2SK241 Y
Q22, Q28, Q7

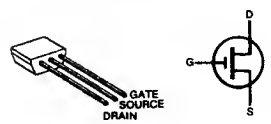

3SK74 K/M
Q2, Q3, Q15, Q21, Q27

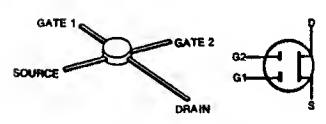

RN1202
Q12, Q23, Q32, Q34, Q51, Q6

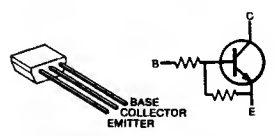

RN1204
Q33, Q39, Q54, Q55

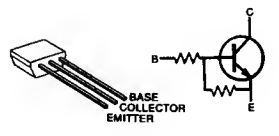

RN2202
Q10, Q20, Q24, Q25, Q41

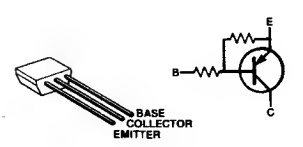

7-3 PLL UNIT

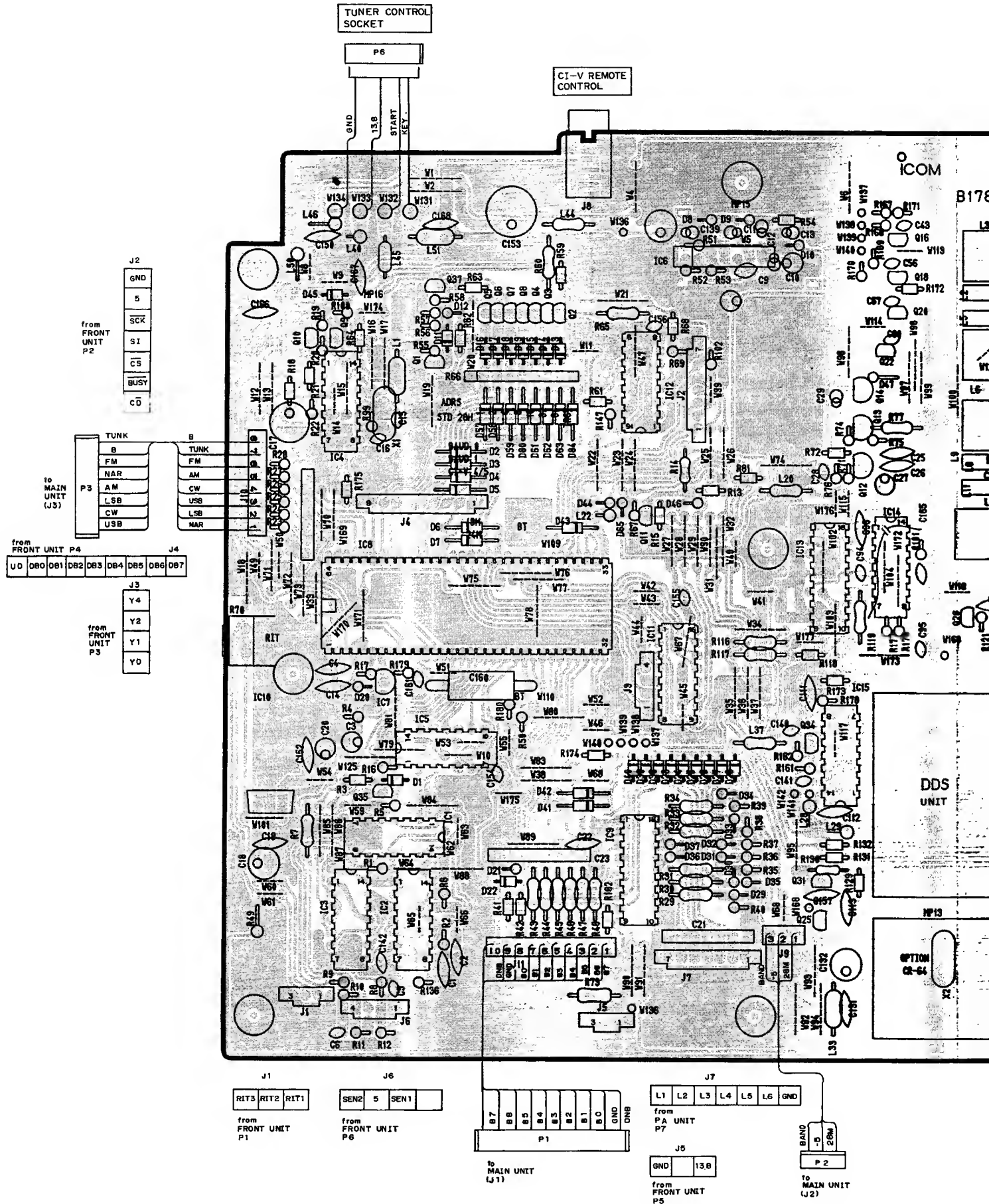

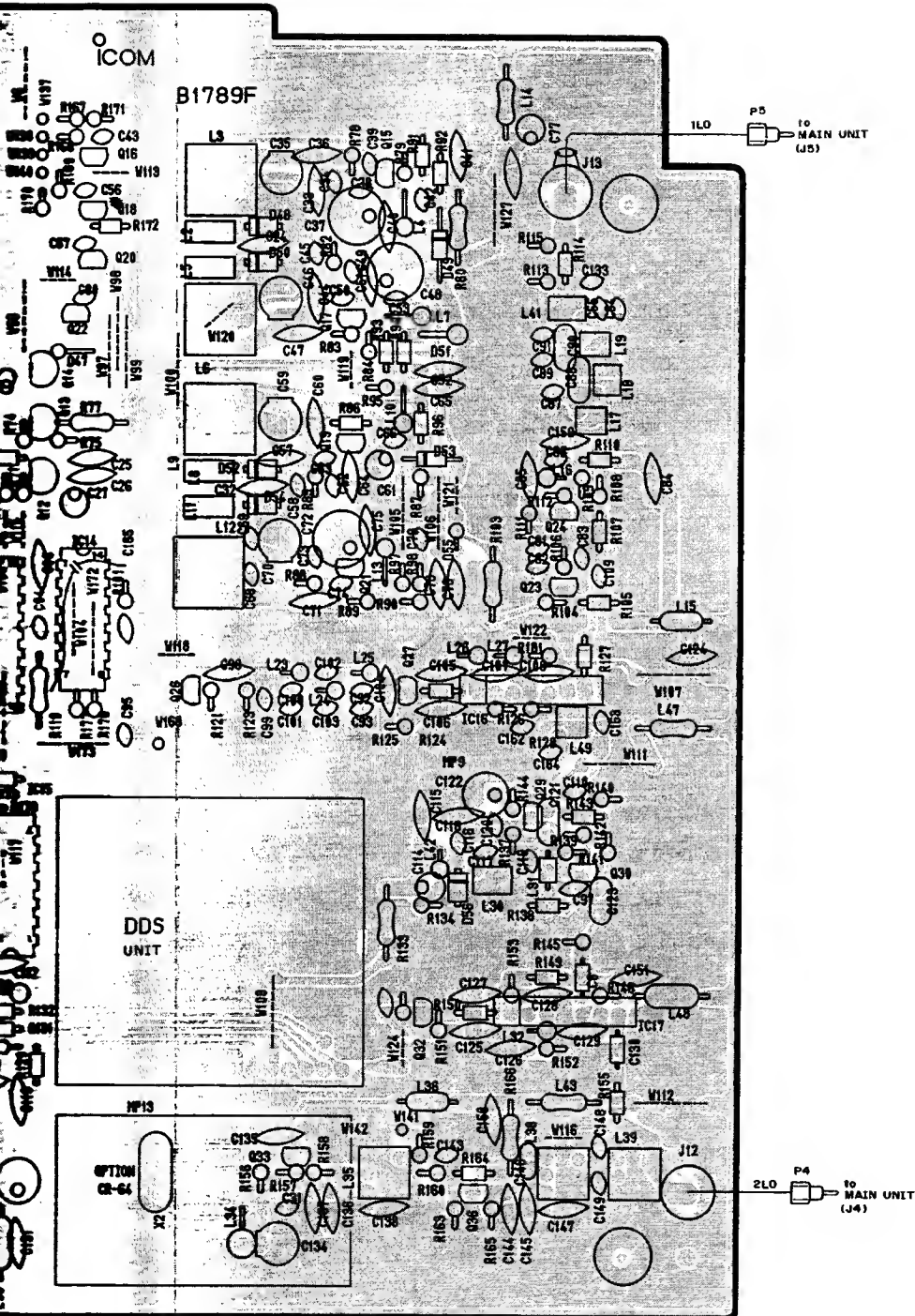

2SA1048 GR
Q37



2SC1571G
Q12

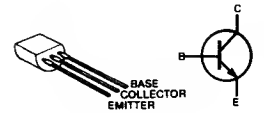

2SC2458 GR/Y
Q1, Q10, Q11,
Q13, Q14, Q16,
Q18, Q2, Q20,
Q22, Q3, Q33,
Q4, Q5, Q6,
Q7, Q8, Q9,
Q32

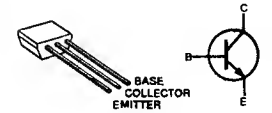

2SC2668 O
Q23, Q24, Q26,
Q27, Q30, Q34,
Q36



2SK192A GR
Q15, Q17, Q19,
Q21, Q29

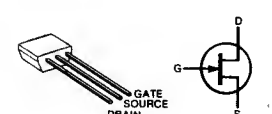

RN1202
Q25, Q35

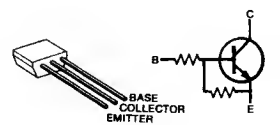

RN2202
Q31

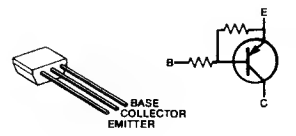

7-4 PA UNIT

• FILTER UNIT

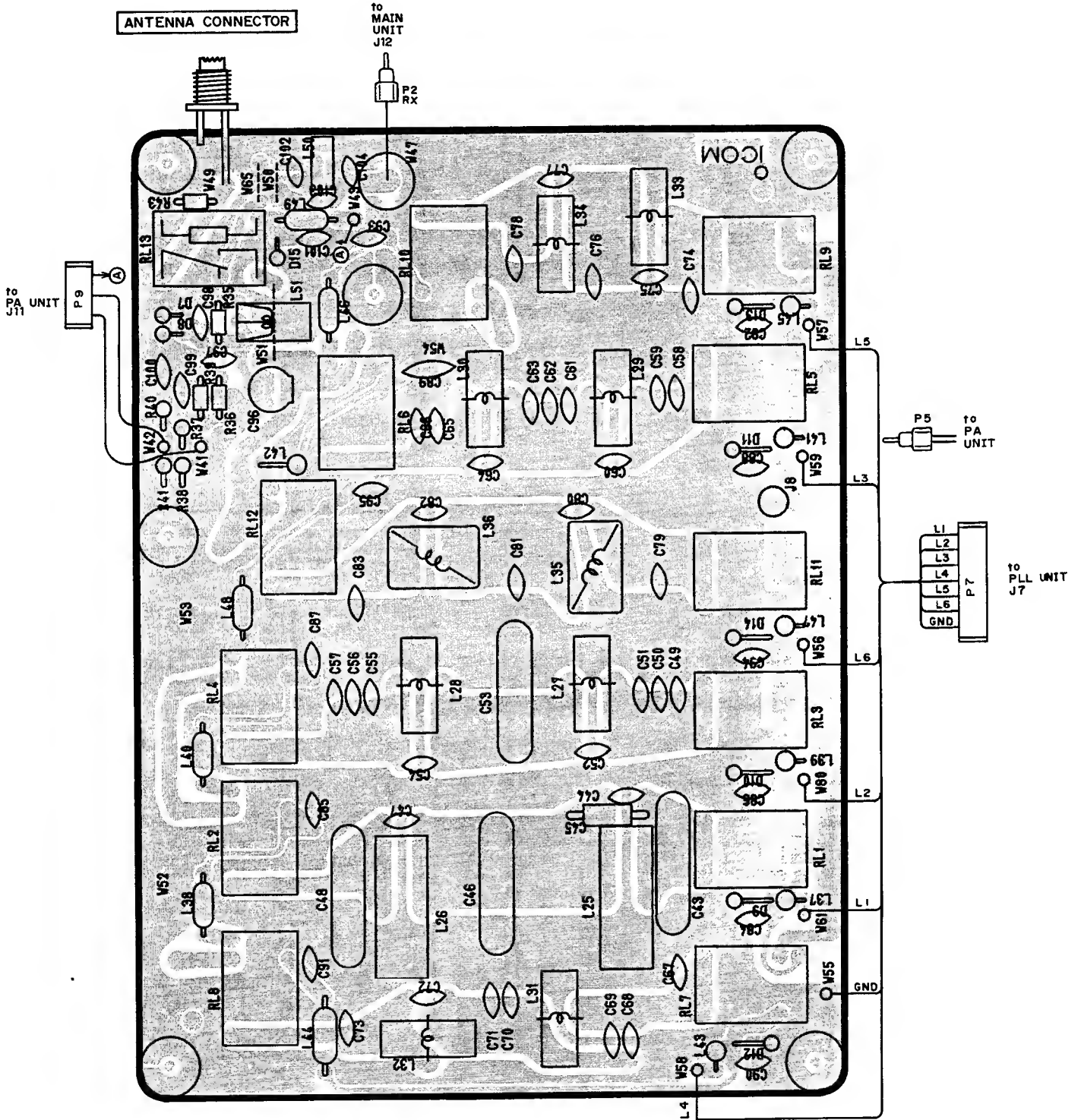

• PA UNIT

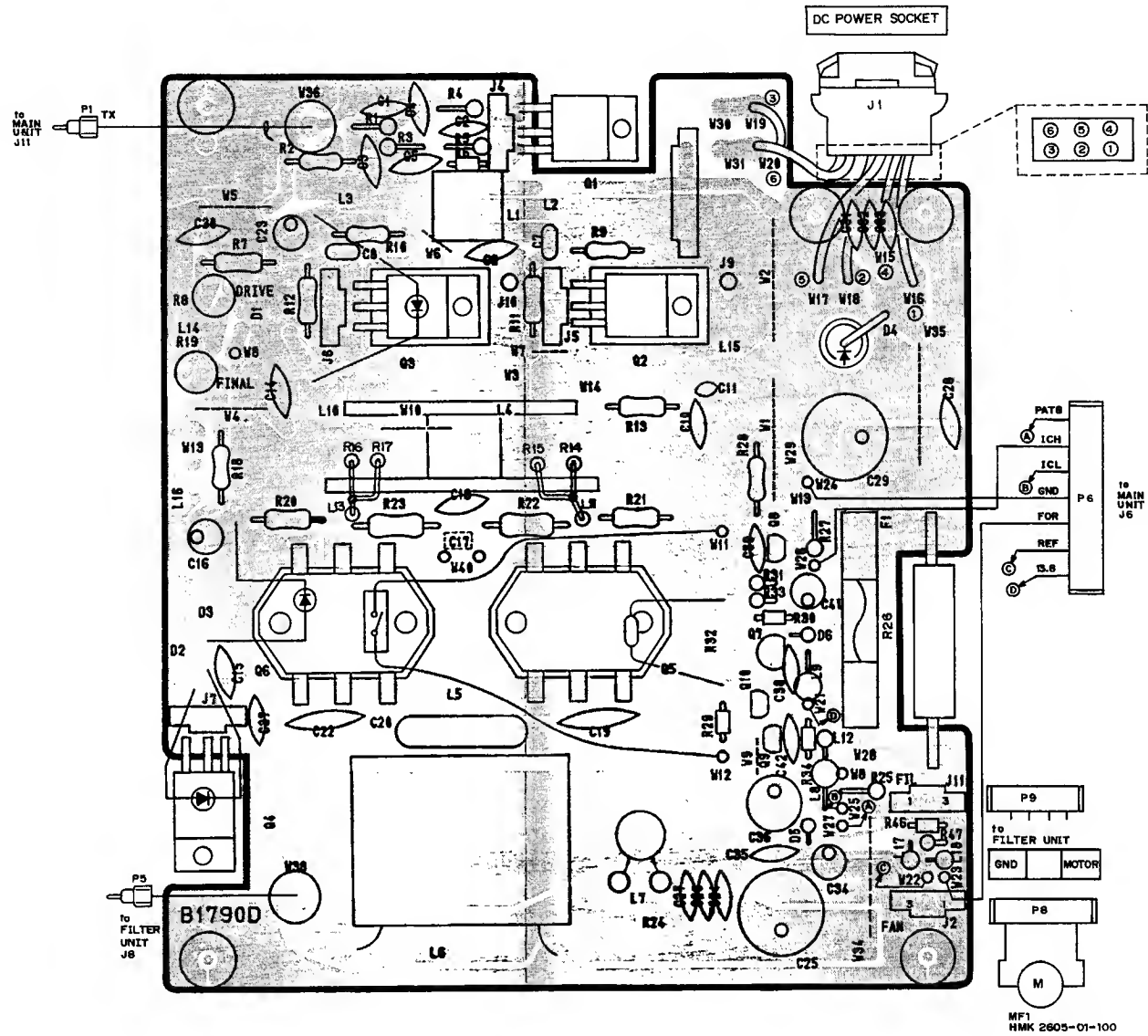

2SB562 C
Q7

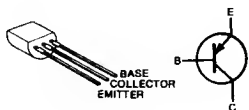

2SC1971
Q1

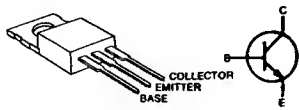

2SC2904
Q5, Q6

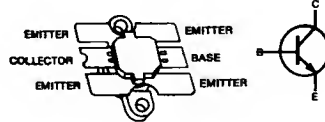

2SC3133
Q2, Q3

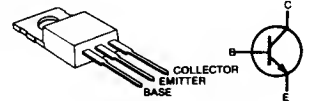

2SD1406 Y
Q4

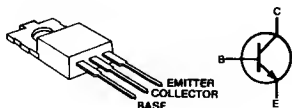

RN1202
Q8, Q9



RN2202
Q10



7-5 DDS UNIT

COMPONENT SIDE

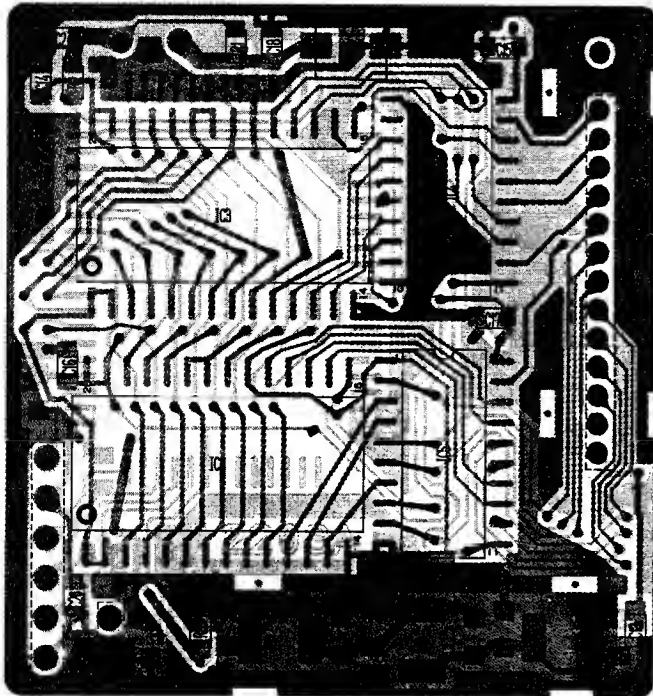

FOIL SIDE
COMPONENT SIDE

FOIL SIDE

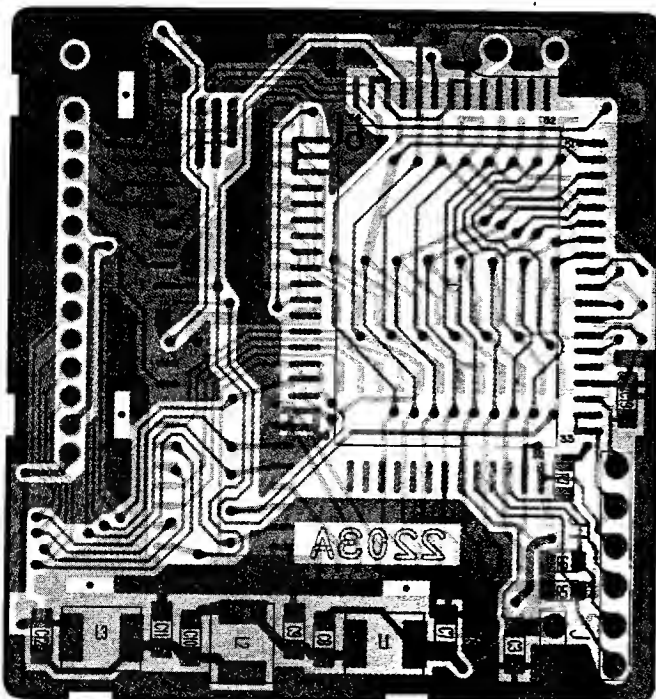

J1
LD
PO
PI
data
CK
ENAL

FOIL SIDE
COMPONENT SIDE

+5V
GND

7-6 AM • FM UNIT (OPTIONAL)

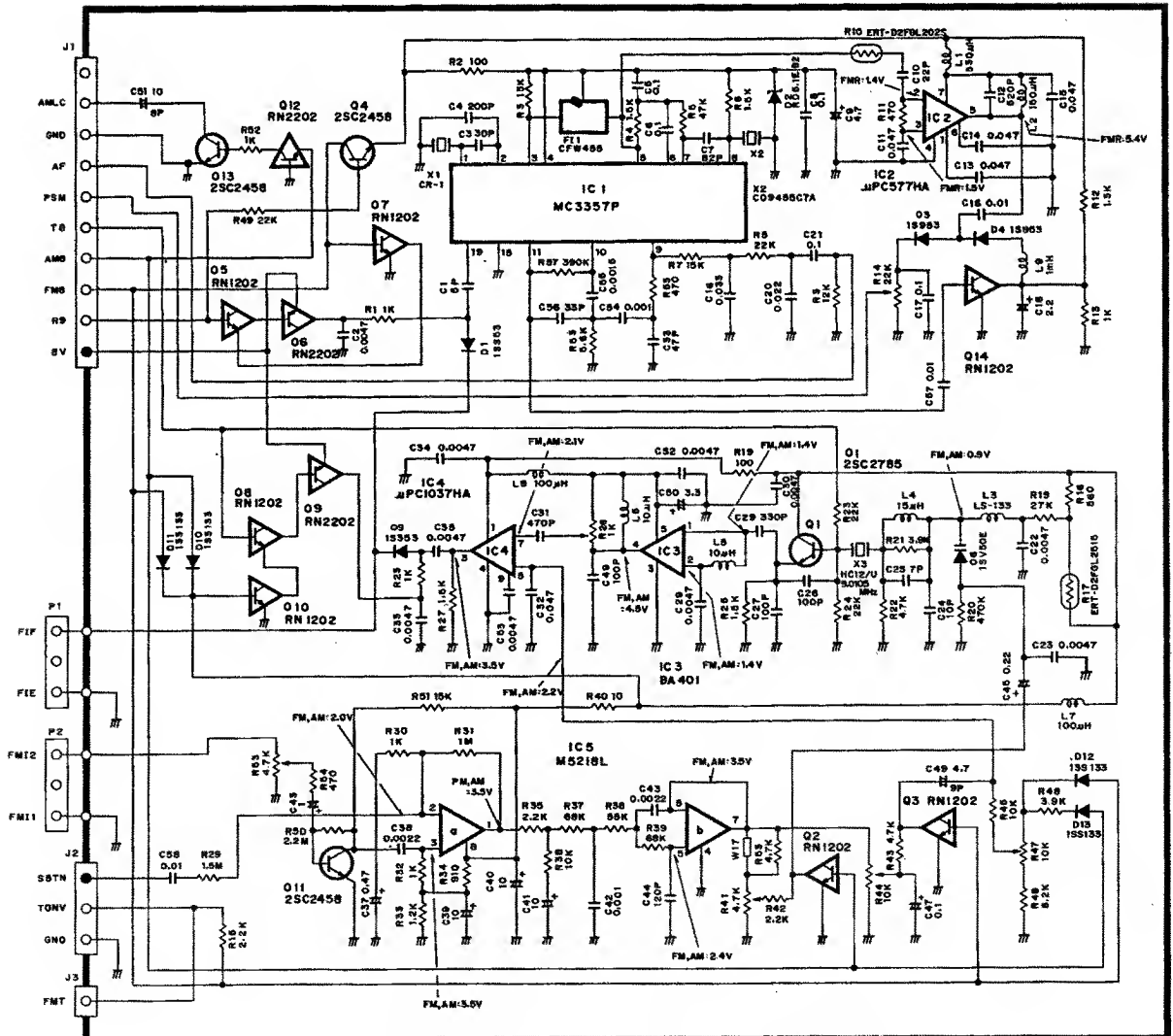
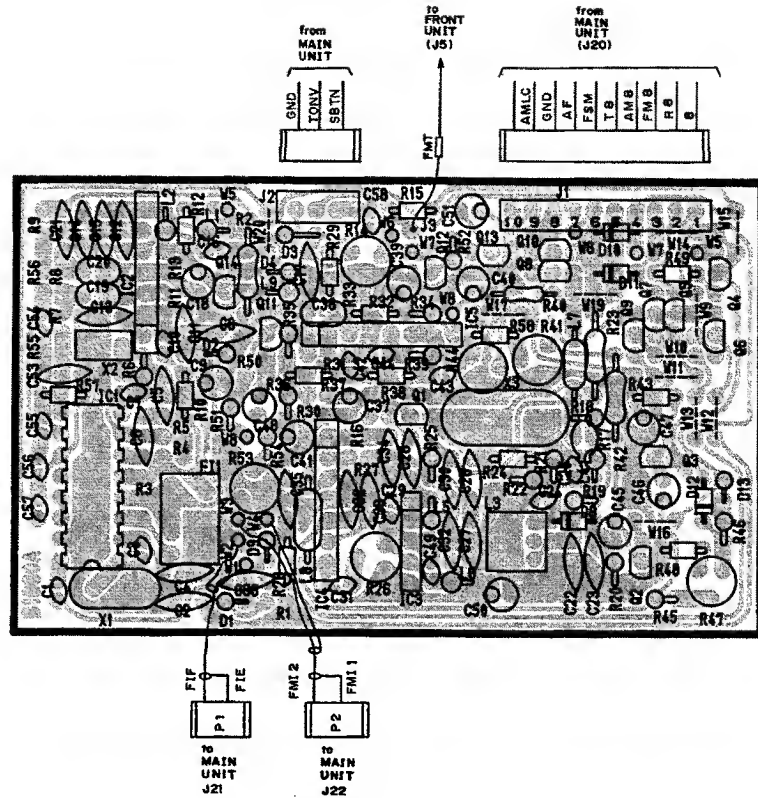

SECTION 8 PARTS LIST

[FRONT UNIT]

REF. NO.	ORDER NO.	DESCRIPTION	
IC1	1130000790	IC	μPD7225G
Q1	1520000230	Transistor	2SB909M Q
Q2	1530000110	Transistor	2SC2458-GR
Q3	1530000110	Transistor	2SC2458-GR
Q4	1530000110	Transistor	2SC2458-GR
Q5	1590000350	Transistor	RN1204
Q6	1530000110	Transistor	2SC2458-GR
D1	1730000180	Zener	RD8.2E B2
D2	1710000160	Diode	1SS133
D3	1710000160	Diode	1SS133
D4	1710000160	Diode	1SS133
D5	1710000180	Diode	1SS133
D6	1710000160	Diode	1SS133
D7	1710000160	Diode	1SS133
D8	1710000160	Diode	1SS133
D9	1710000160	Diode	1SS133
D10	1710000160	Diode	1SS133
D11	1710000160	Diode	1SS133
D12	1710000160	Diode	1SS133
D13	1710000160	Diode	1SS133
D14	1710000160	Diode	1SS133
D15	1710000160	Diode	1SS133
D16	1710000160	Diode	1SS133
D17	1710000160	Diode	1SS133
D18	1710000160	Diode	1SS133
D19	1710000160	Diode	1SS133
L1	6180000900	Coil	LAL 03NA 101K
L2	6180000900	Coil	LAL 03NA 101K
L3	6180000900	Coil	LAL 03NA 101K
L4	6180000900	Coil	LAL 03NA 101K
L5	6180000900	Coil	LAL 03NA 101K
L6	6180000900	Coil	LAL 03NA 101K
L7	6180000900	Coil	LAL 03NA 101K
L8	6180000900	Coil	LAL 03NA 101K
R1	7210001320	Variable Resistor	RK124221002DA (AF/SQ/L)
R2	7210001550	Variable Resistor	RK1242210032A 10KB-10KB (MIC/RF PWR)
R3	7010004030	Resistor	R20J 47 Ω
R4	7010004190	Resistor	R20J 1 kΩ
R5	7010003280	Resistor	ELR20J 100 Ω
R6	7010003280	Resistor	ELR20J 100 Ω
R7	7010004720	Resistor	R50XJ 100 Ω
R8	7010004720	Resistor	R50XJ 100 Ω
R9	7010003400	Resistor	ELR20J 1 kΩ
R10	7010003520	Resistor	ELR20J 8.2 kΩ
R11	7010003480	Resistor	ELR20J 4.7 kΩ
R12	7010003400	Resistor	ELR20J 1 kΩ
R13	7010004250	Resistor	R20J 3.3 kΩ
R14	7010004320	Resistor	R20J 10 kΩ
R15	7010004320	Resistor	R20J 10 kΩ
R16	7010004480	Resistor	R20J 180 kΩ
R17	7010004410	Resistor	R20J 47 kΩ
R18	7010004320	Resistor	R20J 10 kΩ
R19	7010004320	Resistor	R20J 10 kΩ
R20	7010004170	Resistor	R20J 680 Ω
R21	7010004320	Resistor	R20J 10 kΩ
R22	7010004320	Resistor	R20J 10 kΩ
R23	7210000570	Variable Resistor	RK1631110D5FA (RIT)
R24	7010004320	Resistor	R20J 10 kΩ
R25	7010001400	Resistor	R25J 100 kΩ
R26	7010004450	Resistor	R20J 100 kΩ

[FRONT UNIT]

REF. NO.	ORDER NO.	DESCRIPTION	
C1	4510000970	Electrolytic	10 MS9 100 μF
C2	4510001150	Electrolytic	50 MS7 R47 μF
C3	4010000520	Ceramic	DD108 B 472K 50V
C4	4010000520	Ceramic	DD108 B 472K 50V
C5	4040000260	Barrier Layer	UZE 08X 104M
C6	4010000520	Ceramic	DD108 B 472K 50V
C7	4010000520	Ceramic	DD108 B 472K 50V
C8	4020000250	Cylinder	UP125 X 472M
C9	4020000250	Cylinder	UP125 X 472M
C10	4010000520	Ceramic	DD108 B 472K 50V
DS1	5030000380	LCD	HLC9599-01-3210
DS2	5040001290	LED	SLP153B
DS3	5040001300	LED	SLP253B
DS4	5080000170	LED	HRS7219A-Y2-30
DS5	5080000170	LED	HRS7219A-Y2-30
DS7	5080000170	LED	HRS7219A-Y2-30
ME1	5510000300	Meter	KL-218U-43 (M610)
S1	2230000120	Switch	SDDSA3159A [POWER]
S2	2230000550	Switch	SPPH23079A [ATT]
S3	2230000550	Switch	SPPH23079A [PRE]
S4	2230000550	Switch	SPPH23079A [NB]
S5	2230000550	Switch	SPPH23079A [AGC]
S6	2230000550	Switch	SPPH23079A [LOCK]
S7	2230000550	Switch	SPPH23079A [TRANSMIT]
S8	2260000070	Switch	SKHHA013A [M-CH UP]
S9	2260000070	Switch	SKHHA013A [M-CH DOWN]
S10	2260000070	Switch	SKHHA013A [VFO]
S11	2260000070	Switch	SKHHA013A [MEMO]
S12	2260000070	Switch	SKHHA013A [RIT]
S13	2260000070	Switch	SKHHA013A [MW]
S14	2260000070	Switch	SKHHA013A [FUNC]
S15	2260000070	Switch	SKHHA013A [SPLIT]
S16	2260000070	Switch	SKHHA013A [TUNER]
S17	2260000060	Switch	SKHHAJ025A [BAND]
S18	2260000060	Switch	SKHHAJ025A [MHz]
S19	2260000060	Switch	SKHHAJ025A [kHz]
S20	2260000070	Switch	SKHHA013A [AM/FM]
S21	2260000070	Switch	SKHHA013A [CW/N]
S22	2260000070	Switch	SKHHA013A [SSB]
S23	7600000100	Switch	EC24B50B0013A [MAIN]
EP1	0910019544	P.C. Board	B 1786D (SW)
EP2	0910019524	P.C. Board	B 1787D (VR)
EP3	0910019550	P.C. Board	B 1868 (SPEC)
EP4	0910006330	Flexible Cable	B 792
EP5	0910019931	P.C. Board	B 1932A (LED)
EP9	6910000630	Ferrite Bead	FSOH070RN
EP10	6910000630	Ferrite Bead	FSOH070RN
EP11	6910000630	Ferrite Bead	FSOH070RN

[MAIN UNIT]

REF. NO.	ORDER NO.	DESCRIPTION	
IC1	1790000050	IC	ND487C1-3R
IC2	1110001310	IC	μPC577HA

[MAIN UNIT]

REF. NO.	ORDER NO.	DESCRIPTION	
IC4	1110000330	IC	M5218L
IC5	1110001320	IC	μPC1037HA
IC6	1110001320	IC	μPC1037HA
IC8	1130003900	IC	GD4068B
IC9	1110000890	IC	μPC1241H
IC10	1110000330	IC	M5218L
IC11	1110000330	IC	M5218L
IC13	1130003880	IC	GD4011B
IC14	1180000470	IC	NJM7808A
IC15	1110000290	IC	BA618
IC16	1120000970	IC	M54562P
Q1	1530000810	Transistor	2SC2053
Q2	1580000100	FET	3SK74 K
Q3	1580000100	FET	3SK74 K
Q4	1530000810	Transistor	2SC2053
Q5	1520000230	Transistor	2SB909M Q
Q6	1590000340	Transistor	RN1202
Q7	1580000100	FET	2SK241-Y
Q8	1560000130	FET	2SK125
Q9	1560000130	FET	2SK125
Q10	1590000360	Transistor	RN2202
Q11	1530000110	Transistor	2SC2458-GR
Q12	1590000340	Transistor	RN1202
Q13	1580000130	FET	2SK125
Q14	1560000130	FET	2SK125
Q15	1580000110	FET	3SK74 M
Q16	1560000080	FET	2SK192A-Y
Q17	1510000080	Transistor	2SA1048-GR
Q18	1530000110	Transistor	2SC2458-GR
Q19	1530000110	Transistor	2SC2458-GR
Q20	1590000360	Transistor	RN2202
Q21	1580000110	FET	3SK74 M
Q22	1560000100	FET	2SK241-Y
Q23	1590000340	Transistor	RN1202
Q24	1590000360	Transistor	RN2202
Q25	1590000360	Transistor	RN2202
Q26	1530000110	Transistor	2SC2458-GR
Q27	1580000110	FET	3SK74 M
Q28	1560000100	FET	2SK241-Y
Q29	1530000110	Transistor	2SC2458-GR
Q30	1530000110	Transistor	2SC2458-GR
Q31	1530000110	Transistor	2SC2458-GR
Q32	1590000340	Transistor	RN1202
Q33	1590000350	Transistor	RN1204
Q34	1590000340	Transistor	RN1202
Q35	1530000110	Transistor	2SC2458-GR
Q36	1530000110	Transistor	2SC2458-GR
Q37	1530000110	Transistor	2SC2458-GR
Q38	1510000080	Transistor	2SA1048-GR
Q39	1590000350	Transistor	RN1204
Q40	1530000110	Transistor	2SC2458-GR
Q41	1590000360	Transistor	RN2202
Q42	1530000110	Transistor	2SC2458-GR
Q44	1530000110	Transistor	2SC2458-GR
Q45	1530000110	Transistor	2SC2458-GR
Q46	1540000070	Transistor	2SD468C
Q47	1540000070	Transistor	2SD468C
Q48	1540000070	Transistor	2SD468C
Q49	1530000110	Transistor	2SC2458-GR
Q50	1530000110	Transistor	2SC2458-GR
Q51	1590000340	Transistor	RN1202
Q52	1540000150	Transistor	2SD1225M R
Q53	1510000080	Transistor	2SA1048-GR
Q54	1590000350	Transistor	RN1204
Q55	1590000350	Transistor	RN1204
Q56	1530000110	Transistor	2SC2458-GR
D1	1710000050	Diode	1SS53
D2	1710000050	Diode	1SS53
D3	1710000050	Diode	1SS53
D4	1710000050	Diode	1SS53
D5	1710000050	Diode	1SS53

[MAIN UNIT]

REF. NO.	ORDER NO.	DESCRIPTION	
D6	1710000050	Diode	1SS53
D7	1710000050	Diode	1SS53
D8	1710000050	Diode	1SS53
D9	1710000050	Diode	1SS53
D10	1710000160	Diode	1SS133
D11	1710000160	Diode	1SS133
D12	1710000330	Diode	1K60
D13	1710000330	Diode	1K60
D14	1710000160	Diode	1SS133
D15	1710000050	Diode	1SS53
D16	1710000050	Diode	1SS53
D17	1710000160	Diode	1SS133
D18	1710000050	Diode	1SS53
D19	1710000050	Diode	1SS53
D20	1710000050	Diode	1SS53
D21	1710000050	Diode	1SS53
D22	1710000160	Diode	1SS133
D23	1710000050	Diode	1SS53
D24	1710000050	Diode	1SS53
D25	1710000050	Diode	1SS53
D26	1710000050	Diode	1SS53
D27	1710000160	Diode	1SS133
D28	1710000050	Diode	1SS53
D29	1710000050	Diode	1SS53
D30	1710000050	Diode	1SS53
D31	1710000050	Diode	1SS53
D32	1710000050	Diode	1SS53
D33	1710000050	Diode	1SS53
D34	1710000160	Diode	1SS133
D35	1710000050	Diode	1SS53
D36	1710000050	Diode	1SS53
D37	1710000050	Diode	1SS53
D38	1710000050	Diode	1SS53
D39	1710000050	Diode	1SS53
D40	1710000050	Diode	1SS53
D41	1710000050	Diode	1SS53
D42	1710000050	Diode	1SS53
D43	1710000050	Diode	1SS53
D44	1710000050	Diode	1SS53
D45	1710000050	Diode	1SS53
D46	1710000050	Diode	1SS53
D47	1710000050	Diode	1SS53
D48	1710000050	Diode	1SS53
D49	1710000050	Diode	1SS53
D50	1710000050	Diode	1SS53
D51	1710000050	Diode	1SS53
D52	1710000050	Diode	1SS53
D55	1710000160	Diode	1SS133
D56	1710000330	Diode	1K60
D57	1710000160	Diode	1SS133
D58	1710000160	Diode	1SS133
D59	1710000330	Diode	1K60
D60	1710000330	Diode	1K60
D61	1710000160	Diode	1SS133
D62	1710000330	Diode	1K60
D63	1710000050	Diode	1SS53
D64	1710000160	Diode	1SS133
D65	1710000160	Diode	1SS133
D66	1710000160	Diode	1SS133
D67	1710000050	Diode	1SS53
D68	1710000050	Diode	1SS53
D69	1710000050	Diode	1SS53
D70	1710000050	Diode	1SS53
D71	1710000050	Diode	1SS53
D72	1710000160	Diode	1SS133
D73	1710000160	Diode	1SS133
D75	1710000160	Diode	1SS133
D76	1710000160	Diode	1SS133
D77	1710000160	Diode	1SS133
D78	1710000160	Diode	1SS133
D79	1710000160	Diode	1SS133
D80	1730000070	Zener	RD3.9E B2
D81	1710000160	Diode	1SS133
D82	1710000160	Diode	1SS133
D83	1710000160	Diode	1SS133

[MAIN UNIT]

REF. NO.	ORDER NO.	DESCRIPTION	
D84	1710000160	Diode	1SS133
D85	1710000160	Diode	1SS133
D86	1710000160	Diode	1SS133
D87	1710000160	Diode	1SS133
D88	1710000160	Diode	1SS133
D89	1710000160	Diode	1SS133
D90	1710000160	Diode	1SS133
D91	1710000160	Diode	1SS133
D92	1710000160	Diode	1SS133
D93	1710000160	Diode	1SS133
D94	1710000160	Diode	1SS133
D95	1710000160	Diode	1SS133
D96	1710000160	Diode	1SS133
D97	1710000030	Diode	1S1555
D98	1710000160	Diode	1SS133
D99	1710000160	Diode	1SS133
FI1	2010000240	Filter	70M15A (FL-71)
FI2	2010000270	Filter	9M15A (FL-23)
FI3	2010000320	Filter	9M22D2 (FL-30)
FI4	2010000950	Filter	9M6A1 (FL-116)
X1	6050001800	Crystal	CR-49
L1	6140000080	Coil	LR-20
L2	6180000700	Coil	LAL 03NA R27M
L3	6180000710	Coil	LAL 03NA R33M
L4	6180000860	Coil	LAL 03NA 5R6K
L5	6180000960	Coil	LAL 03NA 102K
L6	6140002050	Coil	LR-224
L7	6150001770	Coil	LS-198
L8	6110001620	Coil	LA-245
L9	6180000900	Coil	LAL 03NA 101K
L10	6140001460	Coil	LR-170
L11	6140001260	Coil	LR-151
L12	6180000740	Coil	LAL 03NA R56M
L13	6180000690	Coil	LAL 03NA R22M
L14	6150000990	Coil	LS-114
L16	6150001770	Coil	LS-198
L17	6150001770	Coil	LS-198
L18	6140002060	Coil	LR-225
L19	6140002060	Coil	LR-225
L20	6180000900	Coil	LAL 03NA 101K
L21	6150001640	Coil	LS-180B
L22	6150000700	Coil	LS-90A
L23	6150000700	Coil	LS-90A
L24	6180000950	Coil	LAL 03NA 150K
L25	6150001590	Coil	LS-175
L26	6150001590	Coil	LS-175
L27	6140000640	Coil	LR-86
L28	6140000060	Coil	LR-18
L29	6110001650	Coil	LA-248
L30	6180000700	Coil	LAL 03NA R27M
L31	6140002050	Coil	LR-224
L32	6180000880	Coil	LAL 03NA 100K
L33	6150001770	Coil	LS-198
L34	6150002430	Coil	LS-254
L35	6150002430	Coil	LS-254
L36	6150000990	Coil	LS-114
L37	6150001470	Coil	LS-163
L38	6180000940	Coil	LAL 03NA 270K
L39	6180000930	Coil	LAL 03NA 220K
L40	6180000900	Coil	LAL 03NA 101K
L41	6180000900	Coil	LAL 03NA 101K
L42	6180000850	Coil	LAL 03NA 4R7K
L43	6180000840	Coil	LAL 03NA 3R9K
L44	6180000900	Coil	LAL 03NA 101K
L45	6180000870	Coil	LAL 03NA 6R8K
L46	6180000850	Coil	LAL 03NA 4R7K
L47	6180000900	Coil	LAL 03NA 101K
L48	6180000820	Coil	LAL 03NA 2R7M
L49	6180000810	Coil	LAL 03NA 2R2M

[MAIN UNIT]

REF. NO.	ORDER NO.	DESCRIPTION	
L50	6180000820	Coil	LAL 03NA 2R7M
L51	6180000830	Coil	LAL 03NA 3R3K
L52	6180000900	Coil	LAL 03NA 101K
L53	6180000800	Coil	LAL 03NA 1R8M
L54	6180000780	Coil	LAL 03NA 1R2M
L55	6180000790	Coil	LAL 03NA 1R5M
L56	6180000790	Coil	LAL 03NA 1R5M
L57	6180000900	Coil	LAL 03NA 101K
L58	6180000780	Coil	LAL 03NA 1R2M
L59	6180000770	Coil	LAL 03NA 1R0M
L60	6180000760	Coil	LAL 03NA R82M
L61	6180000760	Coil	LAL 03NA R82M
L62	6180000900	Coil	LAL 03NA 101K
L63	6180000760	Coil	LAL 03NA R82M
L64	6180000750	Coil	LAL 03NA R68M
L65	6180000750	Coil	LAL 03NA R68M
L66	6180000740	Coil	LAL 03NA R56M
L67	6180000900	Coil	LAL 03NA 101K
L68	6180000730	Coil	LAL 03NA R47M
L69	6180000730	Coil	LAL 03NA R47M
L70	6180000730	Coil	LAL 03NA R47M
L71	6180000730	Coil	LAL 03NA R47M
L72	6180000900	Coil	LAL 03NA 101K
L73	6180000700	Coil	LAL 03NA R27M
L74	6180000700	Coil	LAL 03NA R27M
L75	6180000710	Coil	LAL 03NA R33M
L76	6180000710	Coil	LAL 03NA R33M
L77	6150001590	Coil	LS-175
L78	6150001470	Coil	LS-163
L79	6150001590	Coil	LS-175
L80	6170000140	Coil	LW-15
L81	6180000690	Coil	LAL 03NA R22M
L82	6150001220	Coil	LS-134
L83	6150001210	Coil	LS-133A
L85	6180000900	Coil	LAL 03NA 101K
L86	6180000900	Coil	LAL 03NA 101K
L87	6180000900	Coil	LAL 03NA 101K
L88	6180000880	Coil	LAL 03NA 100K
L89	6180000950	Coil	LAL 03NA 150K
L90	6180000950	Coil	LAL 03NA 150K
L91	6180000900	Coil	LAL 03NA 101K
L92	6180000900	Coil	LAL 03NA 101K
L93	6910000670	Coil	BT01RN1-A61-001
L94	6180000900	Coil	LAL 03NA 101K
L95	6180000900	Coil	LAL 03NA 101K
L96	6910000670	Coil	BT01RN1-A61-001
L97	6180000900	Coil	LAL 03NA 101K
L98	6910000670	Coil	BT01RN1-A61-001
L99	6180000900	Coil	LAL 03NA 101K
L100	6180000900	Coil	LAL 03NA 101K
L101	6180000900	Coil	LAL 03NA 101K
L102	6910000670	Coil	BT01RN1-A61-001
L103	6180000900	Coil	LAL 03NA 101K
L104	6180002460	Coil	LAL 02KR 150K
R1	7010004150	Resistor	R20J 470 Ω
R2	7010003960	Resistor	R20J 12 Ω
R3	7010003360	Resistor	ELR20J 470 Ω
R4	7010000950	Resistor	R25J 22 Ω
R5	7010004310	Resistor	R20J 8.2 kΩ
R6	7010003920	Resistor	R20J 5.6 Ω
R7	7010004170	Resistor	R20J 680 Ω
R8	7010003250	Resistor	ELR20J 56 Ω
R9	7010003660	Resistor	ELR20J 100 kΩ
R10	7010003660	Resistor	ELR20J 100 kΩ
R11	7010003530	Resistor	ELR20J 10 kΩ
R12	7010003240	Resistor	ELR20J 47 Ω
R13	7010003200	Resistor	ELR20J 22 Ω
R14	7010004170	Resistor	R20J 680 Ω
R15	7010003490	Resistor	ELR20J 5.6 kΩ
R16	7010003260	Resistor	ELR20J 68 Ω
R17	7010004070	Resistor	R20J 100 Ω
R18	7010004300	Resistor	R20J 6.8 kΩ
R19	7010000790	Resistor	R25J 1 Ω

[MAIN UNIT]

REF. NO.	ORDER NO.	DESCRIPTION
R20	7010004230	Resistor R20J 2.2 kΩ
R21	7010003510	Resistor ELR20J 6.8 kΩ
R22	7010004090	Resistor R20J 150 Ω
R23	7010004270	Resistor R20J 4.7 kΩ
R24	7010003330	Resistor ELR20J 270 Ω
R25	7010003330	Resistor ELR20J 270 Ω
R26	7010003190	Resistor ELR20J 18 Ω
R27	7010003460	Resistor ELR20J 3.3 kΩ
R28	7010004230	Resistor R20J 2.2 kΩ
R29	7010004230	Resistor R20J 2.2 kΩ
R30	7010001190	Resistor R25J 2.2 kΩ
R31	7010003320	Resistor ELR20J 220 Ω
R32	7010000990	Resistor R25J 47 Ω
R33	7010003740	Resistor ELR20J 470 kΩ
R34	7010003580	Resistor ELR20J 22 kΩ
R35	7510000110	Thermistor ERT-D2FGL251S
R36	7010004130	Resistor R20J 330 Ω
R37	7010003280	Resistor ELR20J 100 Ω
R38	7010004450	Resistor R20J 100 kΩ
R39	7010004090	Resistor R20J 150 Ω
R40	7010004070	Resistor R20J 100 Ω
R41	7010003950	Resistor R20J 10 Ω
R42	7010003620	Resistor ELR20J 47 kΩ
R43	7010003660	Resistor ELR20J 100 kΩ
R44	7010001030	Resistor R25J 100 Ω
R45	7010003620	Resistor ELR20J 47 kΩ
R46	7010003660	Resistor ELR20J 100 kΩ
R47	7010003530	Resistor ELR20J 10 kΩ
R48	7010003510	Resistor ELR20J 6.8 kΩ
R49	7010004130	Resistor R20J 330 Ω
R50	7010003580	Resistor ELR20J 22 kΩ
R51	7010003400	Resistor ELR20J 1 kΩ
R52	7010004320	Resistor R20J 10 kΩ
R53	7010004320	Resistor R20J 10 kΩ
R54	7010004230	Resistor R20J 2.2 kΩ
R55	7010004230	Resistor R20J 2.2 kΩ
R56	7010003460	Resistor ELR20J 3.3 kΩ
R57	7010004230	Resistor R20J 2.2 kΩ
R58	7010004070	Resistor R20J 100 Ω
R59	7010004230	Resistor R20J 2.2 kΩ
R60	7010003440	Resistor ELR20J 2.2 kΩ
R61	7010004230	Resistor R20J 2.2 kΩ
R62	7010003440	Resistor ELR20J 2.2 kΩ
R63	7010001030	Resistor R25J 100 Ω
R64	7010004230	Resistor R20J 2.2 kΩ
R65	7010001110	Resistor R25J 470 Ω
R66	7010004110	Resistor R20J 220 Ω
R67	7010003990	Resistor R20J 22 Ω
R68	7010003320	Resistor ELR20J 220 Ω
R69	7010000870	Resistor R25J 4.7 Ω
R70	7010003440	Resistor ELR20J 2.2 kΩ
R71	7010003400	Resistor ELR20J 1 kΩ
R72	7010003400	Resistor ELR20J 1 kΩ
R73	7010003360	Resistor ELR20J 470 Ω
R74	7010003360	Resistor ELR20J 470 Ω
R75	7010003530	Resistor ELR20J 10 kΩ
R76	7010004030	Resistor R20J 47 Ω
R77	7010004090	Resistor R20J 150 Ω
R78	7010001530	Resistor R25J 1 MΩ
R79	7010003990	Resistor R20J 22 Ω
R80	7010004090	Resistor R20J 150 Ω
R81	7010000990	Resistor R25J 47 Ω
R82	7010003440	Resistor ELR20J 2.2 kΩ
R83	7010004230	Resistor R20J 2.2 kΩ
R84	7010004030	Resistor R20J 47 Ω
R85	7310000760	Trimmer RH0651CJ4J01A (223)
R86	7010004070	Resistor R20J 100 Ω
R87	7010004950	Resistor R20J 1.5 MΩ
R88	7010003360	Resistor ELR20J 470 Ω
R89	7510000100	Thermistor ERT-D2FGL601S
R90	7010003530	Resistor ELR20J 10 kΩ
R91	7010004030	Resistor R20J 47 Ω
R92	7010003340	Resistor ELR20J 330 Ω
R93	7010001110	Resistor R25J 470 Ω
R94	7010000330	Resistor ELR25J 470 Ω

[MAIN UNIT]

REF. NO.	ORDER NO.	DESCRIPTION
R95	7010004070	Resistor R20J 100 Ω
R96	7010004070	Resistor R20J 100 Ω
R97	7010004070	Resistor R20J 100 Ω
R98	7010004070	Resistor R20J 100 Ω
R99	7010004070	Resistor R20J 100 Ω
R100	7010004070	Resistor R20J 100 Ω
R101	7410000180	Resistor Array RMX- 8 103K
R102	7010003350	Resistor ELR20J 390 Ω
R103	7010004040	Resistor R20J 56 Ω
R104	7010003620	Resistor ELR20J 47 kΩ
R105	7010000870	Resistor R25J 4.7 Ω
R106	7010004270	Resistor R20J 4.7 kΩ
R107	7010003740	Resistor ELR20J 470 kΩ
R108	7010004370	Resistor R20J 22 kΩ
R109	7010004420	Resistor R20J 56 kΩ
R110	7310000750	Trimmer RH0651C14J2WA (103)
R111	7010004320	Resistor R20J 10 kΩ
R112	7010001030	Resistor R25J 100 Ω
R113	7010003820	Resistor ELR20J 3.3 MΩ
R114	7010004570	Resistor R20J 1 MΩ
R115	7010004370	Resistor R20J 22 kΩ
R116	7310000750	Trimmer RH0651C14J2WA (103)
R117	7010003580	Resistor ELR20J 22 kΩ
R118	7010004610	Resistor R20J 3.3 MΩ
R119	7010003530	Resistor ELR20J 10 kΩ
R120	7010004070	Resistor R20J 100 Ω
R121	7010004320	Resistor R20J 10 kΩ
R122	7010004250	Resistor R20J 3.3 kΩ
R123	7010003360	Resistor ELR20J 470 Ω
R124	7010003480	Resistor ELR20J 4.7 kΩ
R125	7010003550	Resistor ELR20J 15 kΩ
R126	7010003510	Resistor ELR20J 6.8 kΩ
R127	7010003640	Resistor ELR20J 68 kΩ
R128	7010003660	Resistor ELR20J 100 kΩ
R129	7010003400	Resistor ELR20J 1 kΩ
R130	7010004150	Resistor R20J 470 Ω
R131	7010003700	Resistor ELR20J 220 kΩ
R132	7010004340	Resistor R20J 15 kΩ
R133	7010004300	Resistor R20J 6.8 kΩ
R134	7010004250	Resistor R20J 3.3 kΩ
R135	7010003240	Resistor ELR20J 47 Ω
R136	7010004030	Resistor R20J 47 Ω
R137	7010004070	Resistor R20J 100 Ω
R138	7310000740	Trimmer RH0651CS3J2KA (472)
R139	7010003530	Resistor ELR20J 10 kΩ
R140	7510000120	Thermistor ERT-D2FGL332S
R141	7010004070	Resistor R20J 100 Ω
R142	7010003300	Resistor ELR20J 150 Ω
R143	7010004150	Resistor R20J 470 Ω
R144	7010004410	Resistor R20J 47 kΩ
R145	7010001030	Resistor R25J 100 Ω
R146	7010004230	Resistor R20J 2.2 kΩ
R147	7010003440	Resistor ELR20J 2.2 kΩ
R148	7010003530	Resistor ELR20J 10 kΩ
R149	7010003830	Resistor R20J 1 Ω
R150	7010003300	Resistor ELR20J 150 Ω
R151	7010003400	Resistor ELR20J 1 kΩ
R152	7010003530	Resistor ELR20J 10 kΩ
R153	7010004320	Resistor R20J 10 kΩ
R154	7010003530	Resistor ELR20J 10 kΩ
R155	7010004320	Resistor R20J 10 kΩ
R156	7010004190	Resistor R20J 1 kΩ
R157	7010003480	Resistor ELR20J 4.7 kΩ
R158	7010001150	Resistor R25J 1 kΩ
R159	7010003400	Resistor ELR20J 1 kΩ
R160	7010004390	Resistor R20J 33 kΩ
R161	7010003990	Resistor R20J 22 Ω
R162	7010003400	Resistor ELR20J 1 kΩ
R164	7010003660	Resistor ELR20J 100 kΩ
R165	7010004070	Resistor R20J 100 Ω
R166	7010004450	Resistor R20J 100 kΩ
R167	7010001400	Resistor R25J 100 kΩ
R168	7010003660	Resistor ELR20J 100 kΩ
R169	7010003440	Resistor ELR20J 2.2 kΩ
R170	7010004230	Resistor R20J 2.2 kΩ

[MAIN UNIT]

REF. NO.	ORDER NO.	DESCRIPTION
R171	7010003440	Resistor ELR20J 2.2 kΩ
R172	7010004230	Resistor R20J 2.2 kΩ
R173	7010003480	Resistor ELR20J 4.7 kΩ
R174	7010004280	Resistor R20J 3.9 kΩ
R175	7010003420	Resistor ELR20J 1.5 kΩ
R176	7010003660	Resistor ELR20J 100 kΩ
R177	7310000750	Trimmer RH0651C14J2WA (103)
R178	7010003660	Resistor ELR20J 100 kΩ
R179	7310000750	Trimmer RH0651C14J2WA (103)
R180	7010004490	Resistor R20J 220 kΩ
R181	7010003440	Resistor ELR20J 2.2 kΩ
R182	7010003480	Resistor ELR20J 4.7 kΩ
R183	7010003530	Resistor ELR20J 10 kΩ
R184	7010004230	Resistor R20J 2.2 kΩ
R185	7010003720	Resistor ELR20J 330 kΩ
R186	7310000790	Trimmer RH0651C15J1UA (104)
R187	7010004410	Resistor R20J 47 kΩ
R188	7010003620	Resistor ELR20J 47 kΩ
R189	7010001110	Resistor R25J 470 Ω
R190	7010004190	Resistor R20J 1 kΩ
R191	7010004410	Resistor R20J 47 kΩ
R192	7010003620	Resistor ELR20J 47 kΩ
R193	7010004390	Resistor R20J 33 kΩ
R194	7310000750	Trimmer RH0651C14J2WA (103)
R195	7010003600	Resistor ELR20J 33 kΩ
R196	7010003780	Resistor ELR20J 1 MΩ
R197	7010004150	Resistor R20J 470 Ω
R198	7010004570	Resistor R20J 1 MΩ
R199	7010005220	Resistor ELR20J 10 MΩ
R200	7010004570	Resistor R20J 1 MΩ
R201	7010004270	Resistor R20J 4.7 kΩ
R202	7010001110	Resistor R25J 470 Ω
R203	7010004500	Resistor R20J 270 kΩ
R204	7010003720	Resistor ELR20J 330 kΩ
R205	7010003360	Resistor ELR20J 470 Ω
R206	7010003650	Resistor ELR20J 82 kΩ #03
R206	7010003650	Resistor ELR20J 82 kΩ #04
R206	7010003480	Resistor ELR20J 4.7 kΩ #01
R206	7010003480	Resistor ELR20J 4.7 kΩ #02
R207	7010003510	Resistor ELR20J 6.8 kΩ
R208	7310000740	Trimmer RH0651CS3J2KA (472)
R209	7010003530	Resistor ELR20J 10 kΩ
R210	7310000790	Trimmer RH0651C15J1UA (104)
R211	7010004530	Resistor R20J 470 kΩ
R212	7010003480	Resistor ELR20J 4.7 kΩ
R213	7010003810	Resistor ELR20J 2.2 MΩ
R214	7010003360	Resistor ELR20J 470 Ω
R215	7010001050	Resistor R25J 150 Ω
R216	7010003530	Resistor ELR20J 10 kΩ
R217	7010001400	Resistor R25J 100 kΩ
R218	7010004190	Resistor R20J 1 kΩ
R220	7010003740	Resistor ELR20J 470 kΩ
R221	7010003740	Resistor ELR20J 470 kΩ
R222	7010003530	Resistor ELR20J 10 kΩ
R223	7010004070	Resistor R20J 100 Ω
R224	7010003530	Resistor ELR20J 10 kΩ
R225	7010000090	Resistor ELR25J 4.7 Ω
R226	7010000370	Resistor ELR25J 1 kΩ
R227	7010000090	Resistor ELR25J 4.7 Ω
R228	7010000370	Resistor ELR25J 1 kΩ
R229	7010000090	Resistor ELR25J 4.7 Ω
R230	7010003280	Resistor ELR20J 100 Ω
R231	7410000140	Resistor Array RMX- 6 472K
R232	7010004110	Resistor R20J 220 Ω
R233	7010003480	Resistor ELR20J 4.7 kΩ
R234	7010003480	Resistor ELR20J 4.7 kΩ
R235	7010003490	Resistor ELR20J 5.6 kΩ
R236	7010004310	Resistor R20J 8.2 kΩ
R237	7010003380	Resistor ELR20J 680 Ω
R238	7310000860	Trimmer RH1051D13J0JA (102)
R239	7010003540	Resistor ELR20J 12 kΩ
R240	7010003440	Resistor ELR20J 2.2 kΩ
R241	7310000750	Trimmer RH0651C14J2WA (103)
R242	7010004320	Resistor R20J 10 kΩ
R243	7010001030	Resistor R25J 100 Ω

[MAIN UNIT]

REF. NO.	ORDER NO.	DESCRIPTION
R244	7210001540	Variable Resistor RK09K1110AEEFA
R245	7010004320	Resistor R20J 10 kΩ
R246	7010004190	Resistor R20J 1 kΩ
R247	7010004300	Resistor R20J 6.8 kΩ
R248	7010004570	Resistor R20J 1 MΩ
R249	7010001030	Resistor R25J 100 Ω
R250	7010004030	Resistor R20J 47 Ω
R251	7010003440	Resistor ELR20J 2.2 kΩ
R252	7010003660	Resistor ELR20J 100 kΩ
R253	7010003660	Resistor ELR20J 100 kΩ
R254	7010001280	Resistor R25J 10 kΩ
R255	7010004190	Resistor R20J 1 kΩ
R256	7010004270	Resistor R20J 4.7 kΩ
R257	7010003480	Resistor ELR20J 4.7 kΩ
R258	7010001360	Resistor R25J 47 kΩ
R259	7010004270	Resistor R20J 4.7 kΩ
R260	7010003400	Resistor ELR20J 1 kΩ
R261	7010003360	Resistor ELR20J 470 Ω
R262	7010003460	Resistor ELR20J 3.3 kΩ
R263	7010004230	Resistor R20J 2.2 kΩ
R264	7010003580	Resistor ELR20J 22 kΩ
R265	7010003530	Resistor ELR20J 10 kΩ
R266	7010001150	Resistor R25J 1 kΩ
R267	7010003480	Resistor ELR20J 4.7 kΩ
R268	7010003360	Resistor ELR20J 470 Ω
R269	7010003120	Resistor ELR20J 4.7 Ω
R270	7010004300	Resistor R20J 6.8 kΩ
R271	7010004320	Resistor R20J 10 kΩ
R272	7010003380	Resistor ELR20J 680 Ω
R273	7010004450	Resistor R20J 100 kΩ
R274	7010004320	Resistor R20J 10 kΩ
R275	7010003040	Resistor ELR20J 1 Ω
C1	4010000520	Ceramic DD108 B 472K 50V
C2	4040000260	Barrier Layer UZE 08X 104M
C3	4010000380	Ceramic DD107 SL 221J 50V
C4	4010000260	Ceramic DD104 SL 470J 50V
C5	4010000380	Ceramic DD107 SL 221J 50V
C6	4010000150	Ceramic DD104 SL 151J 50V
C7	4010000350	Ceramic DD106 SL 151J 50V
C8	4040000110	Barrier Layer UAT 04X 222K
C9	4040000260	Barrier Layer UZE 08X 104M
C10	4040000130	Barrier Layer UAT 05X 332K
C11	4010000050	Ceramic DD104 SL 030C 50V
C12	4020000730	Cylinder UP050 SL 150J
C13	4010000340	Ceramic DD105 SL 121J 50V
C14	4010000520	Ceramic DD108 B 472K 50V
C15	4010000520	Ceramic DD108 B 472K 50V
C16	4010000020	Ceramic DD104 SL 010C 50V
C17	4010000120	Ceramic DD104 SL 100D 50V
C18	4010000100	Ceramic DD104 SL 080D 50V
C19	4010000020	Ceramic DD104 SL 010C 50V
C20	4010000500	Ceramic DD104 B 102K 50V
C21	4010000330	Ceramic DD105 SL 101J 50V
C23	4010000220	Ceramic DD104 SL 330J 50V
C25	4010000500	Ceramic DD104 B 102K 50V
C26	4010000100	Ceramic DD104 SL 080D 50V
C27	4040000150	Barrier Layer UAT 05X 472K
C28	4010000520	Ceramic DD108 B 472K 50V
C29	4010000500	Ceramic DD104 B 102K 50V
C30	4010000520	Ceramic DD108 B 472K 50V
C31	4010000070	Ceramic DD104 SL 050C 50V
C32	4010000070	Ceramic DD104 SL 050C 50V
C33	4010000300	Ceramic DD104 SL 680J 50V
C34	4010000020	Ceramic DD104 SL 010C 50V
C35	4010000520	Ceramic DD108 B 472K 50V
C36	4010000430	Ceramic DD109 SL 471J 50V
C37	4010000340	Ceramic DD105 SL 121J 50V
C38	4020000030	Cylinder UP125 SL 2R2K
C39	4010000070	Ceramic DD104 SL 050C 50V
C40	4040000260	Barrier Layer UZE 08X 104M
C42	4040000260	Barrier Layer UZE 08X 104M
C43	4010000520	Ceramic DD108 B 472K 50V
C44	4010000520	Ceramic DD108 B 472K 50V

[MAIN UNIT]

REF. NO.	ORDER NO.	DESCRIPTION
C46	4010000520	Ceramic DD108 B 472K 50V
C47	4010000200	Ceramic DD104 SL 270J 50V
C49	4010000520	Ceramic DD108 B 472K 50V
C50	4040000150	Barrier Layer UAT 05X 472K
C51	4510001100	Electrolytic 16 MS7 10 μF
C52	4040000150	Barrier Layer UAT 05X 472K
C53	4040000150	Barrier Layer UAT 05X 472K
C54	4040000150	Barrier Layer UAT 05X 472K
C55	4010000520	Ceramic DD108 B 472K 50V
C56	4010000520	Ceramic DD108 B 472K 50V
C58	4010000340	Ceramic DD105 SL 121J 50V
C59	4010000180	Ceramic DD104 SL 220J 50V
C60	4510001100	Electrolytic 16 MS7 10 μF
C61	4510002640	Electrolytic 25 SS 47 μF
C62	4040000260	Barrier Layer UZE 08X 104M
C84	4010000520	Ceramic DD108 B 472K 50V
C65	4010000520	Ceramic DD108 B 472K 50V
C66	4040000260	Barrier Layer UZE 08X 104M
C67	4040000150	Barrier Layer UAT 05X 472K
C68	4040000150	Barrier Layer UAT 05X 472K
C69	4040000260	Barrier Layer UZE 08X 104M
C70	4040000250	Barrier Layer UAT 08X 473M
C71	4040000250	Barrier Layer UAT 08X 473M
C72	4010000330	Ceramic DD105 SL 101J 50V
C73	4040000250	Barrier Layer UAT 08X 473M
C74	4040000250	Barrier Layer UAT 08X 473M
C75	4040000250	Barrier Layer UAT 08X 473M
C77	4010000330	Ceramic DD105 SL 101J 50V
C78	4010000350	Ceramic DD106 SL 151J 50V
C79	4010000120	Ceramic DD104 SL 100D 50V
C80	4010000320	Ceramic DD104 SL 820J 50V
C81	4040000260	Barrier Layer UZE 08X 104M
C82	4010000120	Ceramic DD104 SL 100D 50V
C83	4010004840	Ceramic DD305 F 104Z 12V
C84	4010004840	Ceramic DD305 F 104Z 12V
C85	4010000500	Ceramic DD104 B 472K 50V
C86	4040000260	Barrier Layer UZE 08X 104M
C87	4010000070	Ceramic DD104 SL 050C 50V
C89	4010000100	Ceramic DD104 SL 080D 50V
C90	4010000100	Ceramic DD104 SL 080D 50V
C91	4040000260	Barrier Layer UZE 08X 104M
C92	4010000520	Ceramic DD108 B 472K 50V
C93	4010000080	Ceramic DD104 SL 060D 50V
C94	4010000520	Ceramic DD108 B 472K 50V
C95	4510001150	Electrolytic 50 MS7 R47 μF
C96	4010000520	Ceramic DD108 B 472K 50V
C97	4510001180	Electrolytic 50 MS7 3R3 μF
C99	4010000520	Ceramic DD108 B 472K 50V
C100	4510002640	Electrolytic 25 SS 47 μF
C101	4040000260	Barrier Layer UZE 08X 104M
C102	4010000500	Ceramic DD104 B 102K 50V
C109	4510001100	Electrolytic 16 MS7 10 μF
C110	4040000190	Barrier Layer UAT 05X 103K
C112	4510001100	Electrolytic 16 MS7 10 μF
C113	4510001160	Electrolytic 50 MS7 1 μF
C114	4010000520	Ceramic DD108 B 472K 50V
C115	4510002640	Electrolytic 25 SS 47 μF
C116	4010000330	Ceramic DD105 SL 101J 50V
C117	4010000350	Ceramic DD106 SL 151J 50V
C118	4010000520	Ceramic DD108 B 472K 50V
C119	4010000520	Ceramic DD108 B 472K 50V
C120	4040000260	Barrier Layer UZE 08X 104M
C121	4010000520	Ceramic DD108 B 472K 50V
C122	4010000520	Ceramic DD108 B 472K 50V
C123	4010000380	Ceramic DD107 SL 221J 50V
C124	4510001140	Electrolytic 50 MS7 R22 μF
C125	4040000250	Barrier Layer UAT 08X 473M
C126	4010000520	Ceramic DD108 B 472K 50V
C127	4010000520	Ceramic DD108 B 472K 50V
C128	4010000350	Ceramic DD106 SL 151J 50V
C129	4010000180	Ceramic DD104 SL 220J 50V
C130	4010000520	Ceramic DD108 B 472K 50V
C132	4010000520	Ceramic DD108 B 472K 50V
C133	4010000520	Ceramic DD108 B 472K 50V
C135	4010000520	Ceramic DD108 B 472K 50V

[MAIN UNIT]

REF. NO.	ORDER NO.	DESCRIPTION
C136	4010000520	Ceramic DD108 B 472K 50V
C137	4010000180	Ceramic DD104 SL 220J 50V
C138	4010000520	Ceramic DD108 B 472K 50V
C139	4010000500	Ceramic DD104 B 102K 50V
C140	4010000520	Ceramic DD108 B 472K 50V
C141	4010000520	Ceramic DD108 B 472K 50V
C142	4010000080	Ceramic DD104 SL 060D 50V
C143	4040000080	Barrier Layer UAT 04X 122K
C144	4040000170	Barrier Layer UAT 05X 682K
C145	4040000460	Barrier Layer RAU 08SA 821K
C146	4040000210	Barrier Layer UAT 06X 153K
C147	4040000090	Barrier Layer UAT 04X 152K
C148	4040000070	Barrier Layer UAT 04X 102K
C149	4020000630	Cylinder UP050 B 101K
C150	4040000070	Barrier Layer UAT 04X 102K
C151	4040000250	Barrier Layer UAT 08X 473M
C152	4040000260	Barrier Layer UZE 08X 104M
C153	4040000260	Barrier Layer UZE 08X 104M
C154	4010000520	Ceramic DD108 B 472K 50V
C155	4040000090	Barrier Layer UAT 04X 152K
C156	4040000110	Barrier Layer UAT 04X 222K
C157	4010000410	Ceramic DD107 SL 331J 50V
C158	4010000520	Ceramic DD108 B 472K 50V
C159	4040000080	Barrier Layer UAT 04X 122K
C160	4010000380	Ceramic DD106 SL 181J 50V
C161	4040000080	Barrier Layer UAT 04X 122K
C162	4040000110	Barrier Layer UAT 04X 222K
C163	4040000210	Barrier Layer UAT 06X 153K
C164	4040000080	Barrier Layer UAT 04X 122K
C165	4040000250	Barrier Layer UAT 08X 473M
C166	4010000520	Ceramic DD108 B 472K 50V
C167	4010000440	Ceramic DD109 SL 511J 50V
C168	4010000330	Ceramic DD105 SL 101J 50V
C169	4010000430	Ceramic DD109 SL 471J 50V
C170	4040000080	Barrier Layer UAT 04X 122K
C171	4040000160	Barrier Layer UAT 05X 562K
C172	4040000460	Barrier Layer RAU 08SA 821K
C173	4040000250	Barrier Layer UAT 08X 473M
C174	4010000520	Ceramic DD108 B 472K 50V
C175	4010000410	Ceramic DD107 SL 331J 50V
C176	4010000270	Ceramic DD104 SL 510J 50V
C177	4010000410	Ceramic DD107 SL 331J 50V
C178	4010000410	Ceramic DD107 SL 331J 50V
C179	4040000120	Barrier Layer UAT 05X 272K
C180	4010000410	Ceramic DD107 SL 331J 50V
C181	4040000250	Barrier Layer UAT 08X 473M
C182	4010000520	Ceramic DD108 B 472K 50V
C183	4010000410	Ceramic DD107 SL 331J 50V
C184	4010000260	Ceramic DD104 SL 470J 50V
C185	4010000380	Ceramic DD107 SL 221J 50V
C186	4010000380	Ceramic DD107 SL 221J 50V
C187	4040000100	Barrier Layer UAT 04X 182K
C188	4010000370	Ceramic DD106 SL 201J 50V
C189	4040000250	Barrier Layer UAT 08X 473M
C190	4010000520	Ceramic DD108 B 472K 50V
C191	4010000380	Ceramic DD107 SL 221J 50V
C192	4010000160	Ceramic DD104 SL 180J 50V
C193	4010000330	Ceramic DD105 SL 101J 50V
C194	4010000380	Ceramic DD107 SL 221J 50V
C195	4040000080	Barrier Layer UAT 04X 122K
C196	4010000350	Ceramic DD106 SL 151J 50V
C197	4040000250	Barrier Layer UAT 08X 473M
C198	4010000520	Ceramic DD108 B 472K 50V
C199	4010000220	Ceramic DD104 SL 330J 50V
C200	4010000340	Ceramic DD105 SL 121J 50V
C201	4010000240	Ceramic DD104 SL 390J 50V
C202	4010000300	Ceramic DD104 SL 680J 50V
C203	4010000340	Ceramic DD105 SL 121J 50V
C204	4040000460	Barrier Layer RAU 08SA 821K
C205	4010000330	Ceramic DD105 SL 101J 50V
C206	4040000250	Barrier Layer UAT 08X 473M
C207	4010000520	Ceramic DD108 B 472K 50V
C208	4530000350	Capacitor Array B8ZC0111-32N
C209	4010000520	Ceramic DD108 B 472K 50V
C210	4510002380	Electrolytic 16 SS 470 μF (10X12.5)

[MAIN UNIT]

REF. NO.	ORDER NO.	DESCRIPTION
C211	4040000260	Barrier Layer UZE 08X 104M
C212	4510003040	Electrolytic 16 SS 100 μF
C213	4510000310	Electrolytic 16 MS16 1000 μF (12.5X16)
C214	4510002640	Electrolytic 25 SS 47 μF
C215	4510002730	Electrolytic 10 SS 100 μF
C216	4040000250	Barrier Layer UAT 08X 473M
C217	4510001140	Electrolytic 50 MS7 R22 μF
C218	4510002730	Electrolytic 10 SS 100 μF
C219	4040000110	Barrier Layer UAT 04X 222K
C220	4310000060	Mylar F2D 50V 223K
C221	4510001100	Electrolytic 16 MS7 10 μF
C222	4510002640	Electrolytic 25 SS 47 μF
C223	4510001170	Electrolytic 50 MS7 2R2 μF
C224	4040000150	Barrier Layer UAT 05X 472K
C225	4510001150	Electrolytic 50 MS7 R47 μF
C226	4040000210	Barrier Layer UAT 06X 153K
C227	4010000520	Ceramic DD108 B 472K 50V
C228	4040000150	Barrier Layer UAT 05X 472K
C229	4040000150	Barrier Layer UAT 05X 472K
C230	4010000840	Ceramic DD105 CH 390J 50V
C231	4010001020	Ceramic DD111 CH 221J 50V
C232	4010001020	Ceramic DD111 CH 221J 50V
C233	4010000520	Ceramic DD108 B 472K 50V
C234	4010000520	Ceramic DD108 B 472K 50V
C235	4010000520	Ceramic DD108 B 472K 50V
C236	4040000250	Barrier Layer UAT 08X 473M
C237	4010000180	Ceramic DD104 SL 220J 50V
C238	4010000520	Ceramic DD108 B 472K 50V
C239	4010000520	Ceramic DD108 B 472K 50V
C240	4010000520	Ceramic DD108 B 472K 50V
C241	4010000220	Ceramic DD104 SL 330J 50V
C242	4310000060	Mylar F2D 50V 223K
C243	4310000060	Mylar F2D 50V 223K
C244	4310000060	Mylar F2D 50V 223K
C245	4510001100	Electrolytic 16 MS7 10 μF
C246	4510002850	Electrolytic 25 SS 22 μF
C247	4040000150	Barrier Layer UAT 05X 472K
C248	4510002640	Electrolytic 25 SS 47 μF
C249	4510001160	Electrolytic 50 MS7 1 μF
C250	4510001170	Electrolytic 50 MS7 2R2 μF
C251	4510001160	Electrolytic 50 MS7 1 μF
C252	4510001160	Electrolytic 50 MS7 1 μF
C253	4010000520	Ceramic DD108 B 472K 50V
C254	4010000520	Ceramic DD108 B 472K 50V
C255	4010000520	Ceramic DD108 B 472K 50V
C256	4010000520	Ceramic DD108 B 472K 50V
C257	4010000520	Ceramic DD108 B 472K 50V
C258	4010000330	Ceramic DD105 SL 101J 50V
C259	4010000520	Ceramic DD108 B 472K 50V
C260	4040000260	Barrier Layer UZE 08X 104M
C261	4510001100	Electrolytic 16 MS7 10 μF
C262	4040000250	Barrier Layer UAT 08X 473M
C263	4010000500	Ceramic DD104 B 102K 50V
C264	4510001160	Electrolytic 50 MS7 1 μF
C265	4040000190	Barrier Layer UAT 05X 103K
C266	4040000190	Barrier Layer UAT 05X 103K
C267	4510001150	Electrolytic 50 MS7 R47 μF
C268	4510001150	Electrolytic 50 MS7 R47 μF
C269	4510002440	Electrolytic 16 SS 220 μF (8X11)
C270	4040000260	Barrier Layer UZE 08X 104M
C271	4510002810	Electrolytic 16 SS 47 μF
C272	4530000350	Capacitor Array B8ZC0111-32N
C273	4510001160	Electrolytic 50 MS7 1 μF
C274	4010000460	Ceramic DD104 B 471K 50V
C275	4010000520	Ceramic DD108 B 472K 50V
C276	4510001770	Electrolytic 16 RBP 10 μF
C277	4510002740	Electrolytic 10 SS 220 μF
C278	4510001190	Electrolytic 50 MS7 4R7 μF
C279	4040000150	Barrier Layer UAT 05X 472K
C280	4040000150	Barrier Layer UAT 05X 472K
C281	4010000240	Ceramic DD104 SL 390J 50V
C282	4010000160	Ceramic DD104 SL 180J 50V
C283	4510001150	Electrolytic 50 MS7 R47 μF
C284	4010000520	Ceramic DD108 B 472K 50V

[MAIN UNIT]

REF. NO.	ORDER NO.	DESCRIPTION
C285	4010000520	Ceramic DD108 B 472K 50V
C286	4010000520	Ceramic DD108 B 472K 50V
C287	4010000520	Ceramic DD108 B 472K 50V
C288	4010000520	Ceramic DD108 B 472K 50V
C289	4010000520	Ceramic DD108 B 472K 50V
C290	4010000520	Ceramic DD108 B 472K 50V
C291	4010000430	Ceramic DD109 SL 471J 50V
C292	4010000520	Ceramic DD108 B 472K 50V
C293	4510001140	Electrolytic 50 MS7 R22 μF
C294	4610001200	Trimmer CVSS3001
C295	4010000500	Ceramic DD104 B 102K 50V
C297	4040000250	Barrier Layer UAT 08X 473M
C298	4040000260	Barrier Layer UZE 08X 104M
C299	4040000260	Barrier Layer UZE 08X 104M
C300	4040000250	Barrier Layer UAT 08X 473M
C301	4010000520	Ceramic DD108 B 472K 50V
RL1	6330000180	Relay MZ-12HG
RL2	6330000560	Relay OUC-SH-114D
S2	2230000700	Switch SPPJ31309A [BK IN]
SO1	6510006640	Switch 50864-1
EP1	0910019635	P.C. Board B 1788E

[PLL UNIT]

REF. NO.	ORDER NO.	DESCRIPTION
IC1	1130000670	IC μPD4071BC
IC2	1130000970	IC μPD4030BC
IC3	1130003870	IC GD4001B
IC4	1130001270	IC μPD4069UBC
IC5	1130003890	IC GD4024B
IC6	1110000240	IC BA222-V
IC7	1110001680	IC S-8054ALB
IC8	1140000910	IC HD63A01Y0G83P
IC9	1120000970	IC M54562P
IC10	1180000340	IC TA78005AP
IC11	1130001360	IC TC4021BP
IC12	1130003860	IC MB4052M-G
IC13	1130002960	IC TC9181P
IC14	1120001620	IC M74ALS74AP
IC15	1120001620	IC M74ALS74AP
IC16	1110001320	IC μPC1037HA
IC17	1110001320	IC μPC1037HA
Q1	1530000110	Transistor 2SC2458-GR
Q2	1530000110	Transistor 2SC2458-GR
Q3	1530000110	Transistor 2SC2458-GR
Q4	1530000110	Transistor 2SC2458-GR
Q5	1530000110	Transistor 2SC2458-GR
Q6	1530000110	Transistor 2SC2458-GR
Q7	1530000110	Transistor 2SC2458-GR
Q8	1530000110	Transistor 2SC2458-GR
Q9	1530000110	Transistor 2SC2458-GR
Q10	1530000110	Transistor 2SC2458-GR
Q11	1530000110	Transistor 2SC2458-GR
Q12	1530000940	Transistor 2SC1571G
Q13	1530000110	Transistor 2SC2458-GR
Q14	1530000110	Transistor 2SC2458-GR

[PLL UNIT]

REF. NO.	ORDER NO.	DESCRIPTION	
Q15	1560000090	FET	2SK192A-GR
Q16	1530000110	Transistor	2SC2458-GR
Q17	1560000090	FET	2SK192A-GR
Q18	1530000110	Transistor	2SC2458-GR
Q19	1560000090	FET	2SK192A-GR
Q20	1530000110	Transistor	2SC2458-GR
Q21	1560000090	FET	2SK192A-GR
Q22	1530000110	Transistor	2SC2458-GR
Q23	1530000150	Transistor	2SC2668-O
Q24	1530000150	Transistor	2SC2668-O
Q25	1590000340	Transistor	RN1202
Q26	1530000150	Transistor	2SC2668-O
Q27	1530000150	Transistor	2SC2668-O
Q29	1560000090	FET	2SK192A-GR
Q30	1530000150	Transistor	2SC2668-O
Q31	1590000360	Transistor	RN2202
Q32	1530000100	Transistor	2SC2458-Y
Q33	1530000110	Transistor	2SC2458-GR
Q34	1530000150	Transistor	2SC2668-O
Q35	1590000340	Transistor	RN1202
Q36	1530000150	Transistor	2SC2668-O
Q37	1510000080	Transistor	2SA1048-GR
D1	1710000160	Diode	1SS133
D3	1710000160	Diode	1SS133
D4	1710000160	Diode	1SS133
D5	1710000160	Diode	1SS133
D8	1710000160	Diode	1SS133
D9	1710000160	Diode	1SS133
D10	1730000100	Zener	RD5.1E B2
D11	1710000160	Diode	1SS133
D12	1710000160	Diode	1SS133
D13	1710000160	Diode	1SS133
D14	1710000160	Diode	1SS133
D15	1710000160	Diode	1SS133
D16	1710000160	Diode	1SS133
D17	1710000160	Diode	1SS133
D18	1710000160	Diode	1SS133
D19	1710000160	Diode	1SS133
D20	1710000160	Diode	1SS133
D21	1710000160	Diode	1SS133
D22	1710000160	Diode	1SS133
D23	1710000160	Diode	1SS133
D24	1710000160	Diode	1SS133
D25	1710000160	Diode	1SS133
D26	1710000160	Diode	1SS133
D27	1710000160	Diode	1SS133
D28	1710000160	Diode	1SS133
D29	1710000050	Diode	1SS53
D30	1710000050	Diode	1SS53
D31	1710000050	Diode	1SS53
D32	1710000050	Diode	1SS53
D33	1710000050	Diode	1SS53
D34	1710000050	Diode	1SS53
D35	1710000160	Diode	1SS133
D36	1710000160	Diode	1SS133
D37	1710000160	Diode	1SS133
D38	1710000160	Diode	1SS133
D39	1710000160	Diode	1SS133
D40	1710000160	Diode	1SS133
D41	1710000160	Diode	1SS133
D42	1710000160	Diode	1SS133
D43	1710000040	Diode	1S953
D44	1710000050	Diode	1SS53
D45	1710000160	Diode	1SS133
D46	1710000160	Diode	1SS133
D47	1710000050	Diode	1SS53
D48	1720000050	Varicap	1SV50E
D49	1710000050	Diode	1SS53
D50	1720000050	Varicap	1SV50E
D51	1710000050	Diode	1SS53
D52	1720000050	Varicap	1SV50E
D53	1710000050	Diode	1SS53
D54	1720000050	Varicap	1SV50E

[PLL UNIT]

REF. NO.	ORDER NO.	DESCRIPTION	
D55	1710000050	Diode	1SS53
D56	1720000050	Varicap	1SV50E
D60	1710000160	Diode	1SS133
D62	1710000160	Diode	1SS133
D64	1710000160	Diode	1SS133
D65	1710000050	Diode	1SS53
X1	6060000120	Crystal	CSA4.91MG
X2	6050001520	Crystal	CR-21
L1	6180000880	Coil	LAL 03NA 100K
L2	6140000580	Coil	LR-79
L3	6130000990	Coil	LB-135
L4	6170000180	Coil	LW-19
L5	6140000580	Coil	LR-79
L6	6130000990	Coil	LB-135
L7	6170000180	Coil	LW-19
L8	6140000580	Coil	LR-79
L9	6130000990	Coil	LB-135
L10	6170000160	Coil	LW-19
L11	6140000580	Coil	LR-79
L12	6130000990	Coil	LB-135
L13	6170000180	Coil	LW-19
L14	6180000900	Coil	LAL 03NA 101K
L15	6180000900	Coil	LAL 03NA 101K
L16	6180000740	Coil	LAL 03NA R56M
L17	6110001560	Coil	LA-236
L16	6110001560	Coil	LA-236
L19	6110001550	Coil	LA-235
L20	6180000900	Coil	LAL 03NA 101K
L22	6180000880	Coil	LAL 03NA 100K
L23	6180000720	Coil	LAL 03NA R39M
L24	6180000700	Coil	LAL 03NA R27M
L25	6160000690	Coil	LAL 03NA R22M
L26	6180000960	Coil	LAL 03NA 102K
L27	6180000900	Coil	LAL 03NA 101K
L28	6180000900	Coil	LAL 03NA 101K
L29	6180000900	Coil	LAL 03NA 101K
L30	6110001650	Coil	LA-248
L31	6170000180	Coil	LW-19
L32	6180000850	Coil	LAL 03NA 4R7K
L33	6910000670	Coil	BT01RN1-A61-001
L34	6170000180	Coil	LW-19
L35	6150000760	Coil	LS-94
L36	6180000900	Coil	LAL 03NA 101K
L37	6180000900	Coil	LAL 03NA 101K
L36	6150000990	Coil	LS-114
L39	6150000990	Coil	LS-114
L40	6910000670	Coil	BT01RN1-A61-001
L41	6110001640	Coil	LA-247
L42	6180000880	Coil	LAL 03NA 100K
L43	6180000900	Coil	LAL 03NA 101K
L44	6910000670	Coil	BT01RN1-A61-001
L45	6180000960	Coil	LAL 03NA 102K
L46	6910000670	Coil	BT01RN1-A61-001
L47	6180000900	Coil	LAL 03NA 101K
L46	6180000960	Coil	LAL 03NA 102K
L49	6110001560	Coil	LA-236
L50	6180000960	Coil	LAL 03NA 102K
L51	6180000960	Coil	LAL 03NA 102K
R1	7010003780	Resistor	ELR20J 1 MΩ
R2	7010003550	Resistor	ELR20J 15 kΩ
R3	7010004320	Resistor	R20J 10 kΩ
R4	7010003810	Resistor	ELR20J 2.2 MΩ
R5	7010003760	Resistor	ELR20J 1 MΩ
R6	7010003550	Resistor	ELR20J 15 kΩ
R7	7010001400	Resistor	R25J 100 kΩ
R8	7010003700	Resistor	ELR20J 220 kΩ
R9	7010003660	Resistor	ELR20J 100 kΩ
R10	7010003700	Resistor	ELR20J 220 kΩ
R11	7010003660	Resistor	ELR20J 100 kΩ

[PLL UNIT]

REF. NO.	ORDER NO.	DESCRIPTION
R12	7010003660	Resistor ELR20J 100 kΩ
R13	7010004320	Resistor R20J 10 kΩ
R14	7010001280	Resistor R25J 10 kΩ
R15	7010004210	Resistor R20J 1.5 kΩ
R16	7010003530	Resistor ELR20J 10 kΩ
R17	7010003620	Resistor ELR20J 47 kΩ
R18	7010004450	Resistor R20J 100 kΩ
R19	7010003620	Resistor ELR20J 47 kΩ
R20	7010003620	Resistor ELR20J 47 kΩ
R21	7010004320	Resistor R20J 10 kΩ
R22	7010003620	Resistor ELR20J 47 kΩ
R23	7010003400	Resistor ELR20J 1 kΩ
R24	7010003400	Resistor ELR20J 1 kΩ
R25	7010003400	Resistor ELR20J 1 kΩ
R26	7010003400	Resistor ELR20J 1 kΩ
R27	7010003400	Resistor ELR20J 1 kΩ
R28	7010003400	Resistor ELR20J 1 kΩ
R29	7010001150	Resistor R25J 1 kΩ
R30	7010001150	Resistor R25J 1 kΩ
R31	7010001150	Resistor R25J 1 kΩ
R32	7010001150	Resistor R25J 1 kΩ
R33	7010001150	Resistor R25J 1 kΩ
R34	7010001150	Resistor R25J 1 kΩ
R35	7010005230	Resistor ELR20J 750 Ω
R36	7010003430	Resistor ELR20J 1.8 kΩ
R37	7010003460	Resistor ELR20J 3.3 kΩ
R38	7010003490	Resistor ELR20J 5.6 kΩ
R39	7010003530	Resistor ELR20J 10 kΩ
R40	7010003480	Resistor ELR20J 4.7 kΩ
R41	7010004190	Resistor R20J 1 kΩ
R42	7010004190	Resistor R20J 1 kΩ
R43	7010001150	Resistor R25J 1 kΩ
R44	7010001150	Resistor R25J 1 kΩ
R45	7010001150	Resistor R25J 1 kΩ
R46	7010001150	Resistor R25J 1 kΩ
R47	7010001150	Resistor R25J 1 kΩ
R48	7010001150	Resistor R25J 1 kΩ
R49	7010004670	Resistor R50XJ 22 Ω
R50	7010003530	Resistor ELR20J 10 kΩ
R51	7010003240	Resistor ELR20J 47 Ω
R52	7010003660	Resistor ELR20J 100 kΩ
R53	7010003530	Resistor ELR20J 10 kΩ
R54	7010004030	Resistor R20J 47 Ω
R55	7010003480	Resistor ELR20J 4.7 kΩ
R56	7010003440	Resistor ELR20J 2.2 kΩ
R57	7010003620	Resistor ELR20J 47 kΩ
R58	7010003620	Resistor ELR20J 47 kΩ
R59	7010004410	Resistor R20J 47 kΩ
R60	7010001400	Resistor R25J 100 kΩ
R61	7010004410	Resistor R20J 47 kΩ
R62	7010004410	Resistor R20J 47 kΩ
R63	7010004410	Resistor R20J 47 kΩ
R64	7010004410	Resistor R20J 47 kΩ
R65	7010001360	Resistor R25J 47 kΩ
R66	7410000180	Resistor Array RMX-8 103K
R67	7010003530	Resistor ELR20J 10 kΩ
R68	7010004410	Resistor R20J 47 kΩ
R69	7010003640	Resistor ELR20J 68 kΩ
R70	7210001530	Variable Resistor RK09K1110AEGA (RIT)
R71	7010003460	Resistor ELR20J 3.3 kΩ
R72	7010004070	Resistor R20J 100 Ω
R73	7010004670	Resistor R50XJ 22 Ω
R74	7010003400	Resistor ELR20J 1 kΩ
R75	7010003700	Resistor ELR20J 220 kΩ
R76	7010003440	Resistor ELR20J 2.2 kΩ
R77	7010001150	Resistor R25J 1 kΩ
R78	7010003660	Resistor ELR20J 100 kΩ
R79	7010003660	Resistor ELR20J 100 kΩ
R80	7010001060	Resistor R25J 180 Ω
R81	7010004090	Resistor R20J 150 Ω
R82	7010003660	Resistor ELR20J 100 kΩ
R83	7010003660	Resistor ELR20J 100 kΩ
R84	7010003310	Resistor ELR20J 180 Ω
R85	7010003660	Resistor ELR20J 100 kΩ
R86	7010004450	Resistor R20J 100 kΩ

[PLL UNIT]

REF. NO.	ORDER NO.	DESCRIPTION
R87	7010003310	Resistor ELR20J 180 Ω
R88	7010003660	Resistor ELR20J 100 kΩ
R89	7010003660	Resistor ELR20J 100 kΩ
R90	7010003310	Resistor ELR20J 180 Ω
R91	7010004090	Resistor R20J 150 Ω
R92	7010004250	Resistor R20J 3.3 kΩ
R93	7010004090	Resistor R20J 150 Ω
R94	7010004250	Resistor R20J 3.3 kΩ
R95	7010003300	Resistor ELR20J 150 Ω
R96	7010004250	Resistor R20J 3.3 kΩ
R97	7010003300	Resistor ELR20J 150 Ω
R98	7010003460	Resistor ELR20J 3.3 kΩ
R99	7010003780	Resistor ELR20J 1 MΩ
R100	7010003780	Resistor ELR20J 1 MΩ
R101	7010003360	Resistor ELR20J 470 Ω
R102	7010003530	Resistor ELR20J 10 kΩ
R103	7010000990	Resistor R25J 47 Ω
R104	7010003480	Resistor ELR20J 4.7 kΩ
R105	7010004110	Resistor R20J 220 Ω
R106	7010003340	Resistor ELR20J 330 Ω
R107	7010003990	Resistor R20J 22 Ω
R108	7010003530	Resistor ELR20J 10 kΩ
R109	7010003580	Resistor ELR20J 22 kΩ
R110	7010004070	Resistor R20J 100 Ω
R111	7010003200	Resistor ELR20J 22 Ω
R112	7010003320	Resistor ELR20J 220 Ω
R113	7010003330	Resistor ELR20J 270 Ω
R114	7010003980	Resistor R20J 18 Ω
R115	7010003330	Resistor ELR20J 270 Ω
R116	7010001150	Resistor R25J 1 kΩ
R117	7010001150	Resistor R25J 1 kΩ
R118	7010004190	Resistor R20J 1 kΩ
R119	7010001070	Resistor R25J 220 Ω
R121	7010003480	Resistor ELR20J 4.7 kΩ
R123	7010003280	Resistor ELR20J 100 Ω
R124	7010004150	Resistor R20J 470 Ω
R125	7010003620	Resistor ELR20J 47 kΩ
R126	7010003420	Resistor ELR20J 1.5 kΩ
R127	7010004110	Resistor R20J 220 Ω
R128	7010003360	Resistor ELR20J 470 Ω
R129	7010004110	Resistor R20J 220 Ω
R130	7010001150	Resistor R25J 1 kΩ
R131	7010004190	Resistor R20J 1 kΩ
R132	7010004190	Resistor R20J 1 kΩ
R133	7010001230	Resistor R25J 4.7 kΩ
R134	7010003160	Resistor ELR20J 10 Ω
R136	7010003580	Resistor ELR20J 22 kΩ
R137	7010003660	Resistor ELR20J 100 kΩ
R138	7010004090	Resistor R20J 150 Ω
R139	7010003440	Resistor ELR20J 2.2 kΩ
R140	7010003530	Resistor ELR20J 10 kΩ
R141	7010003480	Resistor ELR20J 4.7 kΩ
R142	7010003340	Resistor ELR20J 330 Ω
R143	7010004110	Resistor R20J 220 Ω
R144	7010003280	Resistor ELR20J 100 Ω
R145	7010003240	Resistor ELR20J 47 Ω
R146	7010003280	Resistor ELR20J 100 Ω
R147	7010003530	Resistor ELR20J 10 kΩ
R149	7010004070	Resistor R20J 100 Ω
R150	7010004190	Resistor R20J 1 kΩ
R151	7010003600	Resistor ELR20J 33 kΩ
R152	7010003440	Resistor ELR20J 2.2 kΩ
R153	7010003280	Resistor ELR20J 100 Ω
R155	7010004190	Resistor R20J 1 kΩ
R156	7010003480	Resistor ELR20J 4.7 kΩ
R157	7010003550	Resistor ELR20J 15 kΩ
R158	7010003360	Resistor ELR20J 470 Ω
R159	7010003240	Resistor ELR20J 47 Ω
R160	7010003320	Resistor ELR20J 220 Ω
R161	7010003530	Resistor ELR20J 10 kΩ
R162	7010003410	Resistor ELR20J 1.2 kΩ
R163	7010003530	Resistor ELR20J 10 kΩ
R164	7010004370	Resistor R20J 22 kΩ
R165	7010003300	Resistor ELR20J 150 Ω
R166	7010001030	Resistor R25J 100 Ω

[PLL UNIT]

REF. NO.	ORDER NO.	DESCRIPTION	
C135	4010003100	Ceramic	DD106 TH 820J 50V
C136	4010000520	Ceramic	DD108 B 472K 50V
C137	4010000520	Ceramic	DD108 B 472K 50V
C138	4010003100	Ceramic	DD106 TH 820J 50V
C139	4550000320	Tantalum	DN 1V 0R1M
C140	4040000150	Barrier Layer	UAT 05X 472K
C141	4010000500	Ceramic	DD104 B 102K 50V
C142	4010000500	Ceramic	DD104 B 102K 50V
C143	4010000500	Ceramic	DD104 B 102K 50V
C144	4010000380	Ceramic	DD107 SL 221J 50V
C145	4040000260	Barrier Layer	UZE 08X 104M
C146	4010000100	Ceramic	DD104 SL 080D 50V
C147	4010000520	Ceramic	DD108 B 472K 50V
C148	4010000010	Ceramic	DD104 SL 0R5C 50V
C149	4010000100	Ceramic	DD104 SL 080D 50V
C150	4010000520	Ceramic	DD108 B 472K 50V
C151	4040000260	Barrier Layer	UZE 08X 104M
C152	4040000260	Barrier Layer	UZE 08X 104M
C153	4510000310	Electrolytic	16 MS16 1000 µF (12.5X16)
C154	4040000190	Barrier Layer	UAT 05X 103K
C155	4040000190	Barrier Layer	UAT 05X 103K
C156	4040000190	Barrier Layer	UAT 05X 103K
C157	4010000520	Ceramic	DD108 B 472K 50V
C158	4010000520	Ceramic	DD108 B 472K 50V
C159	4010000520	Ceramic	DD108 B 472K 50V
C160	4020000180	Cylinder	UP125 B 471K
C161	4040000190	Barrier Layer	UAT 05X 103K
C162	4010000210	Ceramic	DD104 SL 300J 50V
C163	4010000180	Ceramic	DD104 SL 220J 50V
C164	4010000210	Ceramic	DD104 SL 300J 50V
C165	4020000260	Cylinder	TP125 X 103M
C166	4040000250	Barrier Layer	UAT 08X 473M
C167	4040000250	Barrier Layer	UAT 08X 473M
C168	4040000250	Barrier Layer	UAT 08X 473M
BT1	3020000020	Lithium Battery	BR2032-1T2
EP1	6910000600	Ferrite Bead	FSOH050RN
EP2	0910019436	P.C. Board	B 1789F

[DDS UNIT]

REF. NO.	ORDER NO.	DESCRIPTION	
IC1	1140000500	IC	SC1051
IC2	1130002600	IC	SC1052
IC3	1130002610	IC	SC1053
IC4	1130002460	IC	TC74HCT374F
IC5	1130002460	IC	TC74HCT374F
X1	6050003230	Crystal	CR-180
L1	6200000040	Coil	LQN 5N 331K
L2	6200000040	Coil	LQN 5N 331K
L3	6200000040	Coil	LQN 5N 331K
R1	7030000740	Resistor	MCR10EZHZ 1 MΩ (105)
R2	7030000360	Resistor	MCR10EZHZ 680 Ω (681)
R3	7030000420	Resistor	MCR10EZHZ 2.2 kΩ (222)
R4	7410000320	Resistor Array	GF 5096
R5	7030000500	Resistor	MCR10EZHZ 10 kΩ (103)
R6	7030000500	Resistor	MCR10EZHZ 10 kΩ (103)
R7	7030000500	Resistor	MCR10EZHZ 10 kΩ (103)

[DDS UNIT]

REF. NO.	ORDER NO.	DESCRIPTION	
C1	4610000520	Trimmer	TZB04N100BA006
C2	4030000950	Ceramic	GRM40 CH 330J 50PT
C3	4030001150	Ceramic	GRM40 F 104Z 25PT
C7	4030000720	Ceramic	GRM40 SL 680J 50PT
C8	4030000560	Ceramic	GRM40 SL 020C 50PT
C9	4030000750	Ceramic	GRM40 SL 121J 50PT
C10	4030000610	Ceramic	GRM40 SL 070D 50PT
C11	4030000750	Ceramic	GRM40 SL 121J 50PT
C12	4030000640	Ceramic	GRM40 SL 120J 50PT
C13	4030000720	Ceramic	GRM40 SL 680J 50PT
C14	4030001150	Ceramic	GRM40 F 104Z 25PT
C15	4030001150	Ceramic	GRM40 F 104Z 25PT
C16	4030001150	Ceramic	GRM40 F 104Z 25PT
C17	4030001150	Ceramic	GRM40 F 104Z 25PT
C18	4030002430	Ceramic	GRM40 TH 220J 50PT
C19	4030001100	Ceramic	GRM40 B 102K 50PT
C20	4030001100	Ceramic	GRM40 B 102K 50PT
EP1	0910022511	P.C. Board	B 2203A

[PA UNIT]

REF. NO.	ORDER NO.	DESCRIPTION	
Q1	1530000790	Transistor	2SC1971
Q2	1530000190	Transistor	2SC3133
Q3	1530000190	Transistor	2SC3133
Q4	1540000200	Transistor	2SD1406 Y
Q5	1530000200	Transistor	2SC2904
Q6	1530000200	Transistor	2SC2904
Q7	1520000060	Transistor	2SB562C
Q8	1590000340	Transistor	RN1202
Q9	1590000340	Transistor	RN1202
Q10	1590000360	Transistor	RN2202
D1	1790000010	Diode	MV5
D2	1790000010	Diode	MV5
D3	1790000010	Diode	MV5
D4	1710000010	Diode	15CD11
D5	1710000030	Diode	1S1555
D6	1710000030	Diode	1S1555
D7	1710000330	Diode	1K60
D8	1710000330	Diode	1K60
D9	1710000030	Diode	1S1555
D10	1710000030	Diode	1S1555
D11	1710000030	Diode	1S1555
D12	1710000030	Diode	1S1555
D13	1710000030	Diode	1S1555
D14	1710000030	Diode	1S1555
D15	1710000030	Diode	1S1555
L1	6140001170	Coil	LR-142
L2	6910000670	Coil	BT01RN1-A61-001
L3	6910000670	Coil	BT01RN1-A61-001
L4	6140001300	Coil	LR-155
L5	6140000610	Coil	LR-83
L6	6140001310	Coil	LR-156
L7	6140001210	Coil	LR-146
L8	6180001230	Coil	LAL 04NA 8R2K
L9	6180001570	Coil	LAL 04NA 4R7K
L10	6910000670	Coil	BT01RN1-A61-001
L11	6910000670	Coil	BT01RN1-A61-001
L12	6180000880	Coil	LAL 03NA 100K
L13	6910000670	Coil	BT01RN1-A61-001
L14	6910000670	Coil	BT01RN1-A61-001
L15	6910000670	Coil	BT01RN1-A61-001

[PA UNIT]

REF. NO.	ORDER NO.	DESCRIPTION
L16	6910000670	Coil BT01RN1-A61-001
L17	6180000900	Coil LAL 03NA 101K
L18	6180000900	Coil LAL 03NA 101K
L25	6140001110	Coil LR-136
L26	6140001120	Coil LR-137
L27	6140001780	Coil LR-214
L28	6140001790	Coil LR-215
L29	6140001800	Coil LR-216
L30	6140001800	Coil LR-216
L31	6140001810	Coil LR-217
L32	6140001820	Coil LR-218
L33	6140001320	Coil LR-157
L34	6140001330	Coil LR-158
L35	6110001490	Coil LA-196
L36	6110001500	Coil LA-197
L37	6180000900	Coil LAL 03NA 101K
L38	6180000900	Coil LAL 03NA 101K
L39	6180000900	Coil LAL 03NA 101K
L40	6180000900	Coil LAL 03NA 101K
L41	6180000900	Coil LAL 03NA 101K
L42	6180000900	Coil LAL 03NA 101K
L43	6180000900	Coil LAL 03NA 101K
L44	6180000900	Coil LAL 03NA 101K
L45	6180000880	Coil LAL 03NA 100K
L46	6180000880	Coil LAL 03NA 100K
L47	6180000880	Coil LAL 03NA 100K
L48	6180000880	Coil LAL 03NA 100K
L49	6180000900	Coil LAL 03NA 101K
L50	6140001460	Coil LR-170
L51	6140001340	Coil LR-163
R1	7010000310	Resistor ELR25J 330 Ω
R2	7010001050	Resistor R25J 150 Ω
R3	7010000290	Resistor ELR25J 220 Ω
R4	7010000330	Resistor ELR25J 470 Ω
R5	7010004830	Resistor R50XJ 4.7 Ω
R6	7010004120	Resistor R20J 270 Ω
R7	7010004730	Resistor R50XJ 120 Ω
R8	7310000680	Trimmer RH0651C12J04A (101)
R9	7010000990	Resistor R25J 47 Ω
R10	7010000990	Resistor R25J 47 Ω
R11	7010004730	Resistor R50XJ 120 Ω
R12	7010004730	Resistor R50XJ 120 Ω
R13	7010004650	Resistor R50XJ 10 Ω
R14	7080000650	Resistor RSS1P 3R3 Ω
R15	7080000650	Resistor RSS1P 3R3 Ω
R16	7080000650	Resistor RSS1P 3R3 Ω
R17	7080000650	Resistor RSS1P 3R3 Ω
R18	7010004730	Resistor R50XJ 120 Ω
R19	7310000710	Trimmer RH0651C13J1YA (102)
R20	7010004650	Resistor R50XJ 10 Ω
R21	7010004650	Resistor R50XJ 10 Ω
R22	7080000650	Resistor RSS1P 3R3 Ω
R23	7080000650	Resistor RSS1P 3R3 Ω
R24	7070000250	Resistor CRH200 R-02J 4.7 Ω (4R7)
R25	7010000370	Resistor ELR25J 1 kΩ
R26	7100000510	Resistor CP-5AJ 0.012 Ω
R27	7010000370	Resistor ELR25J 1 kΩ
R28	7010001090	Resistor R25J 330 Ω
R29	7010004150	Resistor R20J 470 Ω
R30	7010004190	Resistor R20J 1 kΩ
R31	7010003490	Resistor ELR20J 5.6 kΩ
R32	7510000070	Thermistor ERT-D2FHL503S
R33	7010003610	Resistor ELR20J 39 kΩ
R34	7010004020	Resistor R20J 39 Ω
R35	7010004060	Resistor R20J 82 Ω
R36	7010004270	Resistor R20J 4.7 kΩ
R37	7010003550	Resistor ELR20J 15 kΩ
R38	7010003660	Resistor ELR20J 100 kΩ
R39	7010004270	Resistor R20J 4.7 kΩ
R40	7010003550	Resistor ELR20J 15 kΩ
R41	7010003660	Resistor ELR20J 100 kΩ
R42	7540000010	Absorber DSA-301LA
R43	7010004390	Resistor R20J 33 kΩ

[PA UNIT]

REF. NO.	ORDER NO.	DESCRIPTION
R46	7010004310	Resistor R20J 8.2 kΩ
R47	7010003520	Resistor ELR20J 8.2 kΩ
C1	4010000520	Ceramic DD108 B 472K 50V
C2	4010000510	Ceramic DD106 B 222K 50V
C3	4040000250	Barrier Layer UAT 08X 473M
C4	4040000250	Barrier Layer UAT 08X 473M
C5	4040000250	Barrier Layer UAT 08X 473M
C6	4040000250	Barrier Layer UAT 08X 473M
C7	4310000110	Mylar F2D 50V 472K
C8	4310000110	Mylar F2D 50V 472K
C9	4010000380	Ceramic DD107 SL 221J 50V
C10	4040000250	Barrier Layer UAT 08X 473M
C11	4010000500	Ceramic DD104 B 102K 50V
C12	4030001370	Ceramic GR44 CH 682K
C13	4030001370	Ceramic GR44 CH 682K
C14	4040000250	Barrier Layer UAT 08X 473M
C15	4040000250	Barrier Layer UAT 08X 473M
C16	4510002720	Electrolytic 10 SS 47 μF
C17	4030001340	Ceramic GR44 CH 102K
C18	4010000420	Ceramic DD108 SL 391J 50V
C19	4010004070	Ceramic DD12 SL 221K 500V
C20	4320000220	Dip Mica DM19C 681J5
C21	4030001340	Ceramic GR44 CH 102K
C22	4010004070	Ceramic DD12 SL 221K 500V
C23	4510002640	Electrolytic 25 SS 47 μF
C24	4010000520	Ceramic DD108 B 472K 50V
C25	4510000310	Electrolytic 16 MS16 1000 μF (12.5X16)
C26	4040000260	Barrier Layer UZE 08X 104M
C27	4010000380	Ceramic DD107 SL 221J 50V
C28	4040000250	Barrier Layer UAT 08X 473M
C29	4510000310	Electrolytic 16 MS16 1000 μF (12.5X16)
C30	4040000250	Barrier Layer UAT 08X 473M
C31	4040000260	Barrier Layer UZE 08X 104M
C32	4010000380	Ceramic DD107 SL 221J 50V
C33	4010000520	Ceramic DD108 B 472K 50V
C34	4510002780	Electrolytic 16 SS 10 μF
C35	4010000520	Ceramic DD108 B 472K 50V
C36	4510002440	Electrolytic 16 SS 220 μF (8X11)
C37	4040000250	Barrier Layer UAT 08X 473M
C38	4010000520	Ceramic DD108 B 472K 50V
C39	4010000520	Ceramic DD108 B 472K 50V
C40	4030001340	Ceramic GR44 CH 102K
C41	4510002640	Electrolytic 25 SS 47 μF
C42	4010000520	Ceramic DD108 B 472K 50V
C43	4320000290	Dip Mica DM20C 152J5
C44	4010004040	Ceramic DD10 SL 151K 500V
C45	4010004100	Ceramic DD14 SL 331K 500V
C46	4320000330	Dip Mica DM20C 272J5
C47	4010004030	Ceramic DD10 SL 121K 500V
C48	4320000290	Dip Mica DM20C 152J5
C49	4010004070	Ceramic DD12 SL 221K 500V
C50	4010004050	Ceramic DD12 SL 181K 500V
C51	4010004040	Ceramic DD10 SL 151K 500V
C52	4010004070	Ceramic DD12 SL 221K 500V
C53	4320000280	Dip Mica DM20C 122J5
C54	4010003990	Ceramic DD09 SL 680K 500V
C55	4010004070	Ceramic DD12 SL 221K 500V
C56	4010004070	Ceramic DD12 SL 221K 500V
C57	4010004070	Ceramic DD12 SL 221K 500V
C58	4010004070	Ceramic DD12 SL 221K 500V
C59	4010004050	Ceramic DD12 SL 181K 500V
C60	4010004010	Ceramic DD09 SL 101K 500V
C61	4010004070	Ceramic DD12 SL 221K 500V
C62	4010004070	Ceramic DD12 SL 221K 500V
C63	4010004070	Ceramic DD12 SL 221K 500V
C64	4010003950	Ceramic DD06 SL 330K 500V
C65	4010004070	Ceramic DD12 SL 221K 500V
C66	4010004050	Ceramic DD12 SL 181K 500V
C67	4010004030	Ceramic DD10 SL 121K 500V
C68	4010004000	Ceramic DD09 SL 820K 500V
C69	4010003930	Ceramic DD06 SL 270K 500V

[PA UNIT]

REF. NO.	ORDER NO.	DESCRIPTION	
C70	4010004030	Ceramic	DD10 SL 121K 500V
C71	4010004050	Ceramic	DD12 SL 181K 500V
C72	4010003960	Ceramic	DD06 SL 390K 500V
C73	4010004050	Ceramic	DD12 SL 181K 500V
C74	4010004010	Ceramic	DD09 SL 101K 500V
C75	4010003870	Ceramic	DD06 SL 120K 500V
C76	4010004070	Ceramic	DD12 SL 221K 500V
C77	4010003950	Ceramic	DD06 SL 330K 500V
C78	4010004010	Ceramic	DD09 SL 101K 500V
C79	4010003990	Ceramic	DD09 SL 680K 500V
C80	4010003960	Ceramic	DD06 SL 390K 500V
C81	4010004040	Ceramic	DD10 SL 151K 500V
C82	4010003870	Ceramic	DD06 SL 120K 500V
C83	4010003990	Ceramic	DD09 SL 680K 500V
C84	4040000250	Barrier Layer	UAT 08X 473M
C85	4040000250	Barrier Layer	UAT 08X 473M
C86	4040000250	Barrier Layer	UAT 08X 473M
C87	4040000250	Barrier Layer	UAT 08X 473M
C88	4040000250	Barrier Layer	UAT 08X 473M
C89	4040000250	Barrier Layer	UAT 08X 473M
C90	4010000520	Ceramic	DD108 B 472K 50V
C91	4010000520	Ceramic	DD108 B 472K 50V
C92	4010000520	Ceramic	DD108 B 472K 50V
C93	4010000520	Ceramic	DD108 B 472K 50V
C94	4010000520	Ceramic	DD108 B 472K 50V
C95	4010000520	Ceramic	DD108 B 472K 50V
C96	4610001120	Trimmer	CVSSC2001
C97	4010000410	Ceramic	DD107 SL 331J 50V
C98	4010000410	Ceramic	DD107 SL 331J 50V
C99	4010000430	Ceramic	DD109 SL 471J 50V
C100	4010000430	Ceramic	DD109 SL 471J 50V
C101	4040000250	Barrier Layer	UAT 08X 473M
C102	4010000330	Ceramic	DD105 SL 101J 50V
C103	4010000120	Ceramic	DD104 SL 100D 50V
C104	4010000330	Ceramic	DD105 SL 101J 50V
RL1	6330000180	Relay	MZ-12HG
RL2	6330000180	Relay	MZ-12HG
RL3	6330000180	Relay	MZ-12HG
RL4	6330000180	Relay	MZ-12HG
RL5	6330000180	Relay	MZ-12HG
RL6	6330000180	Relay	MZ-12HG
RL7	6330000180	Relay	MZ-12HG
RL8	6330000180	Relay	MZ-12HG
RL9	6330000180	Relay	MZ-12HG
RL10	6330000180	Relay	MZ-12HG
RL11	6330000180	Relay	MZ-12HG
RL12	6330000180	Relay	MZ-12HG
RL13	6330000720	Relay	DS1-M-DC12V (AG2013)
F1	5210000130	Fuse	FGB 4A
F2	5220000020	Holder	S-N5051
F3	5220000020	Holder	S-N5051
S1	6910000060	Thermostat	OHD-3 90M
SP1	2510000040	Speaker	C065K12I0810
MF1	2710000160	Fan Motor	HMK2605-01-100
EP1	6910000600	Ferrite Bead	FSOH050RN
EP2	6910000600	Ferrite Bead	FSOH050RN
EP3	6910000600	Ferrite Bead	FSOH050RN
EP4	6910000600	Ferrite Bead	FSOH050RN
EP5	6910000600	Ferrite Bead	FSOH050RN
EP6	6910000600	Ferrite Bead	FSOH050RN
EP13	0910019444	P.C. Board	B 1790D (PA)
EP14	0910018743	P.C. Board	B 1791C (FILTER)
EP15	6910000600	Ferrite Bead	FSOH050RN

[PA UNIT]

REF. NO.	ORDER NO.	DESCRIPTION	
EP16	6910000600	Ferrite Bead	FSOH050RN
EP20	6910000630	Ferrite Bead	FSOH070RN
EP21	6910000630	Ferrite Bead	FSOH070RN
EP33	6910000630	Ferrite Bead	FSOH070RN

SECTION 9 VOLTAGE DIAGRAMS

9-1 FRONT AND MAIN UNITS

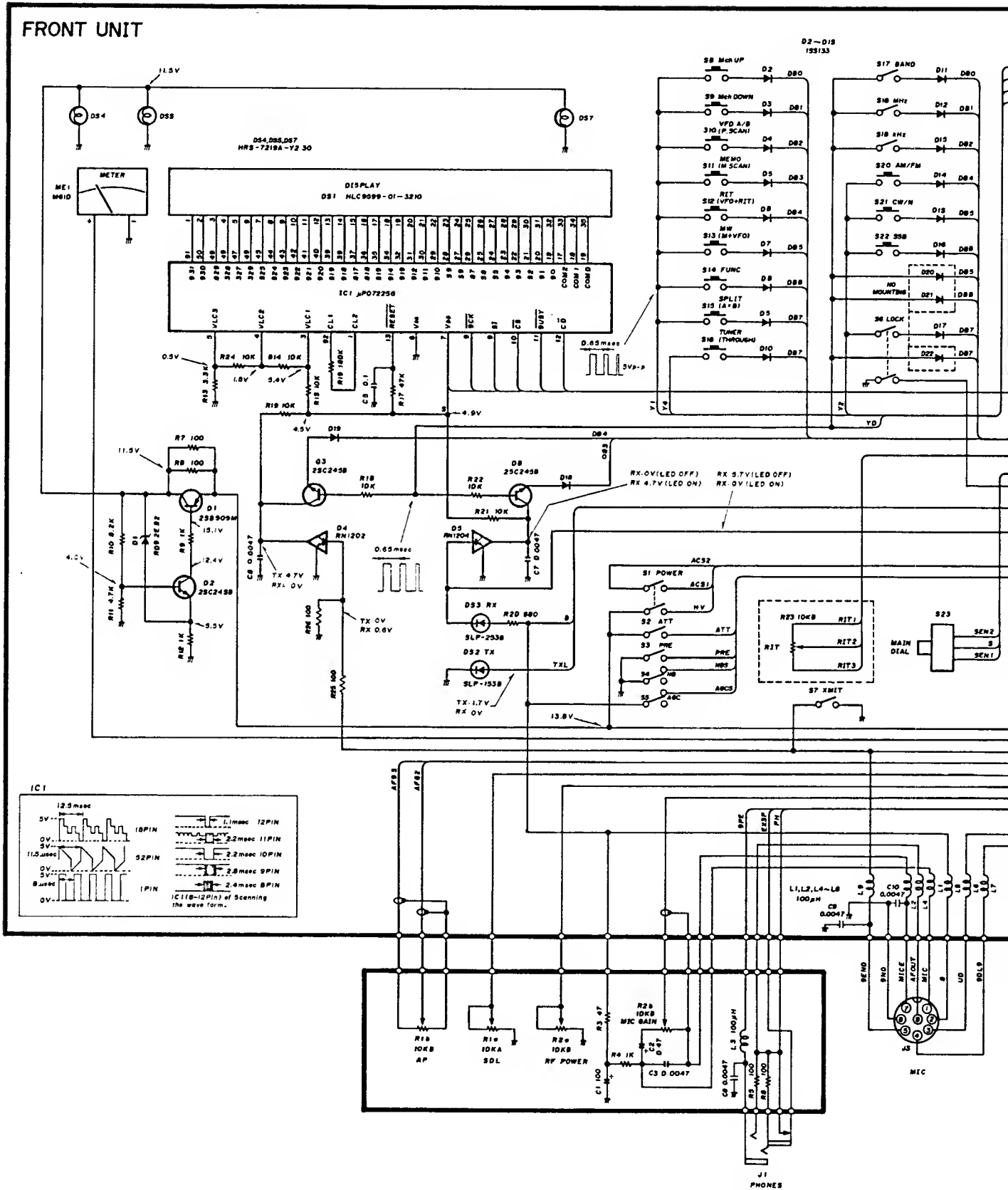

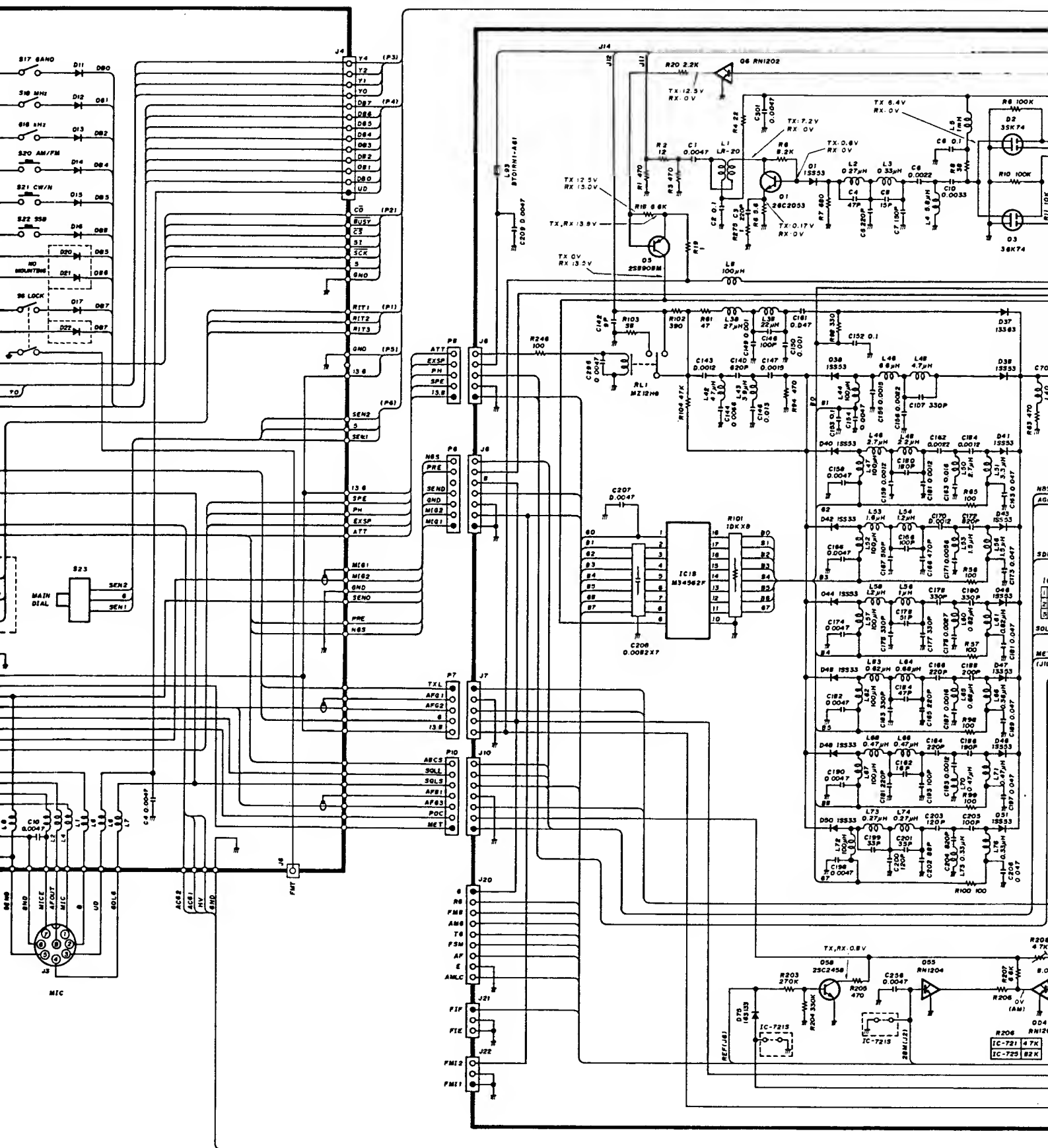

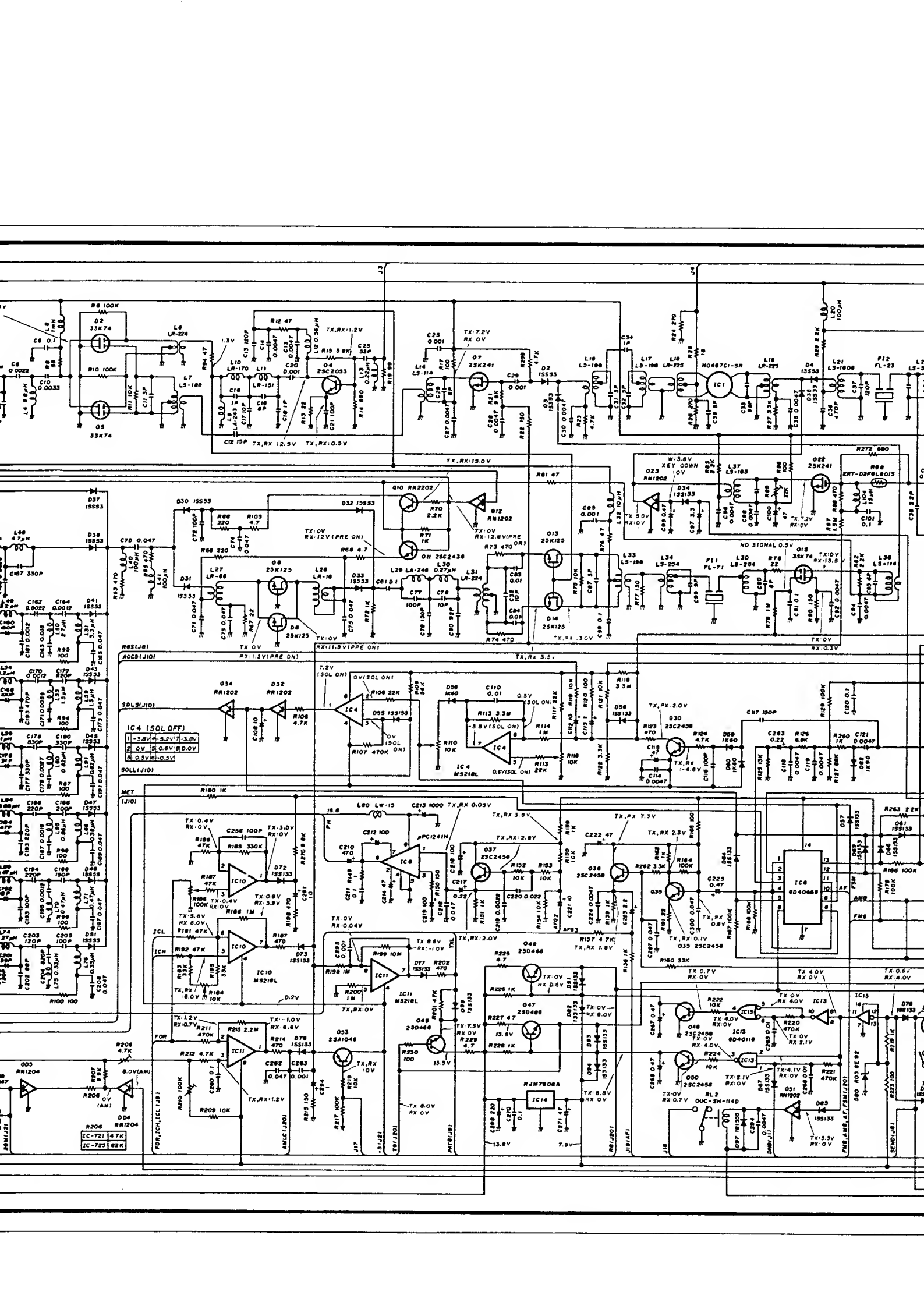

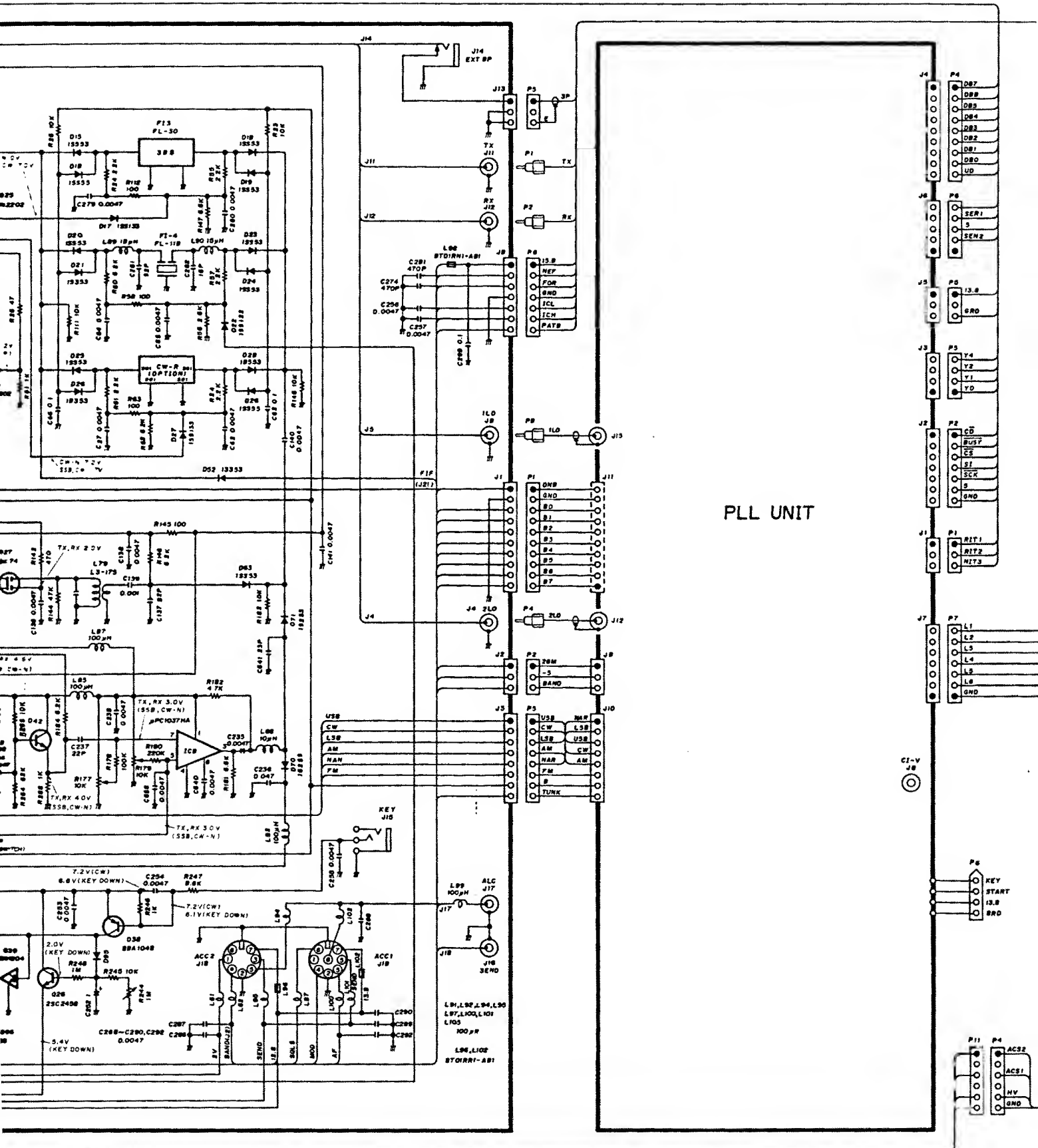

PLL UNIT

FRONT AND MAIN UNITS

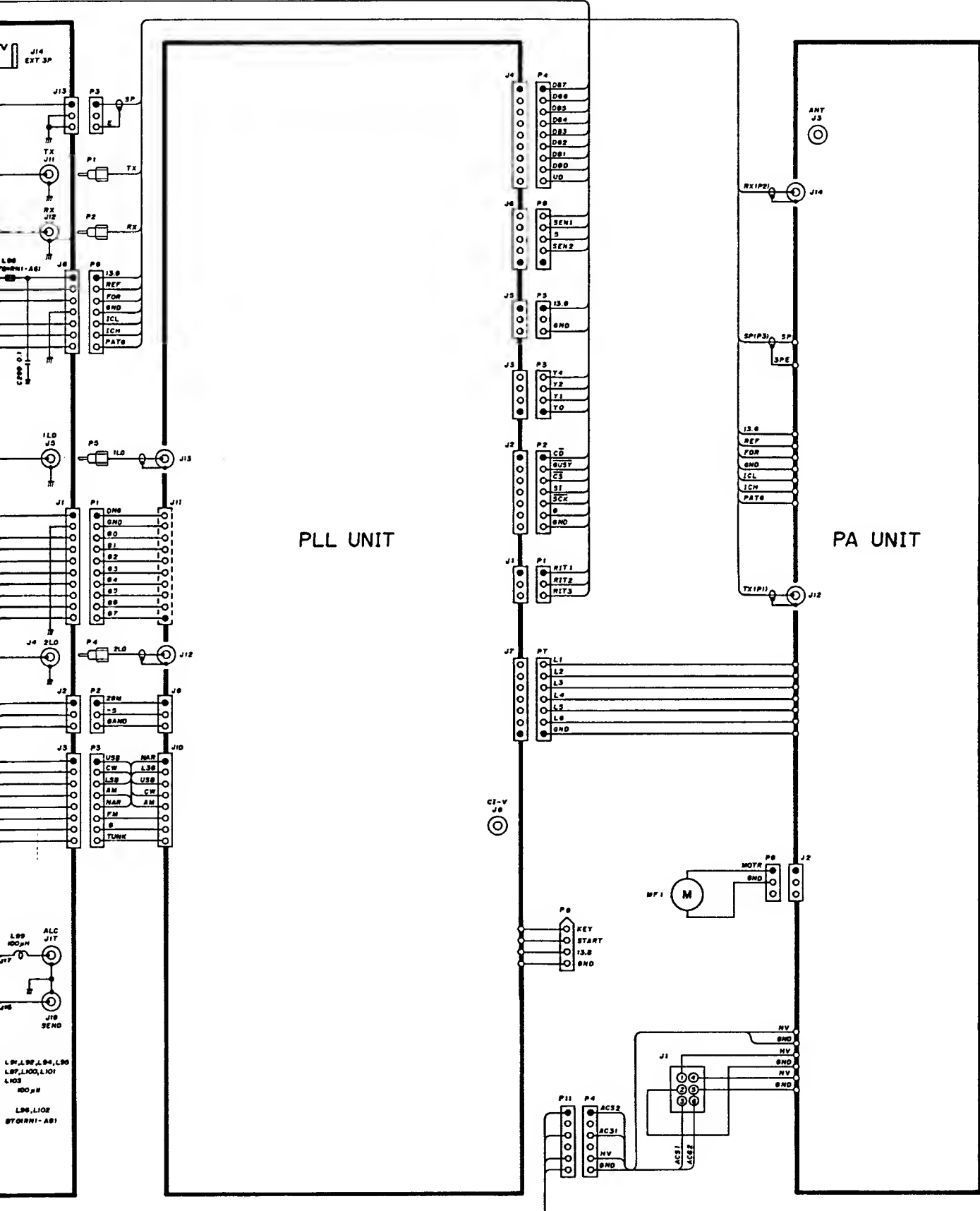

9-2 PLL AND PA UNITS

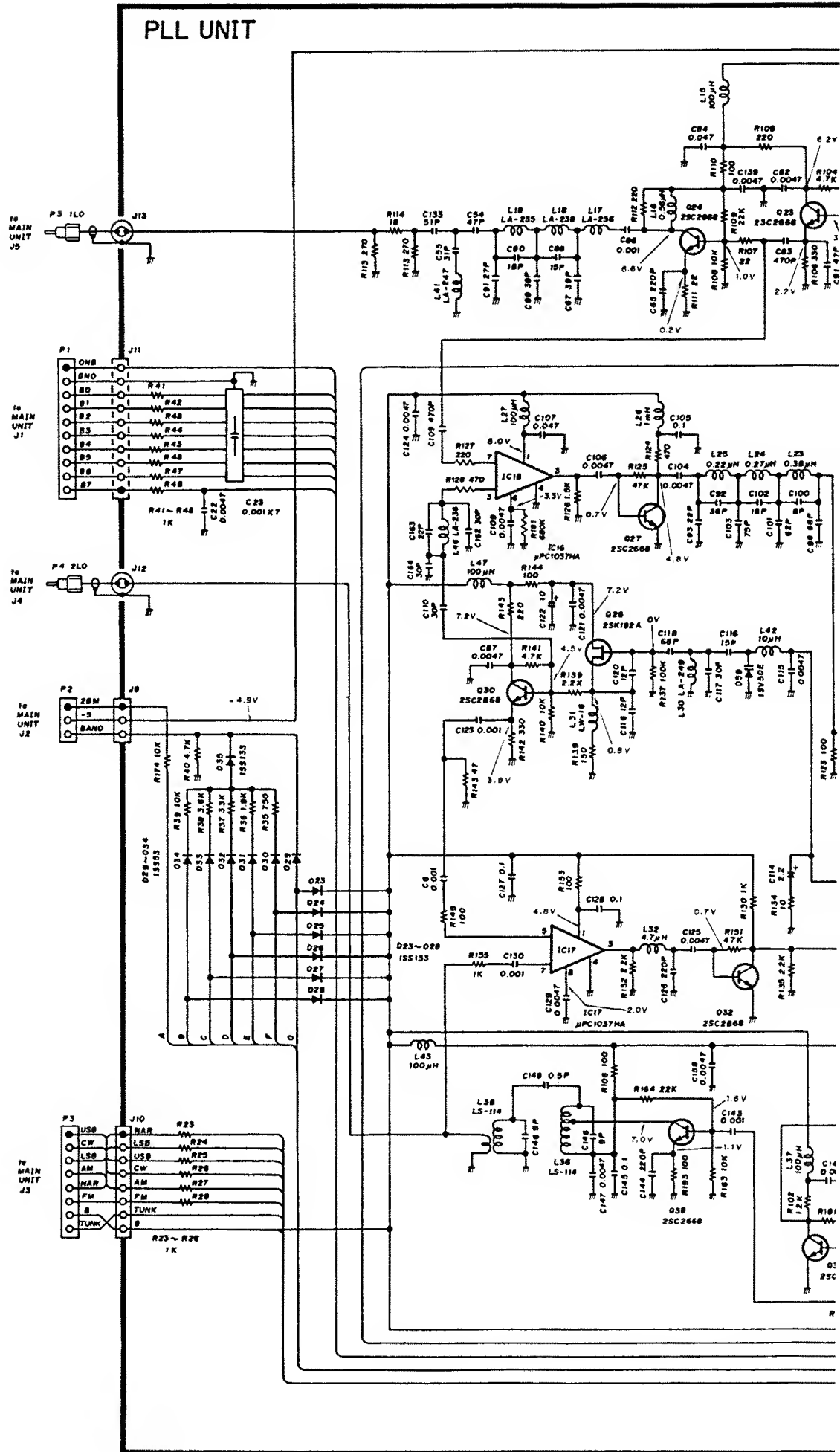

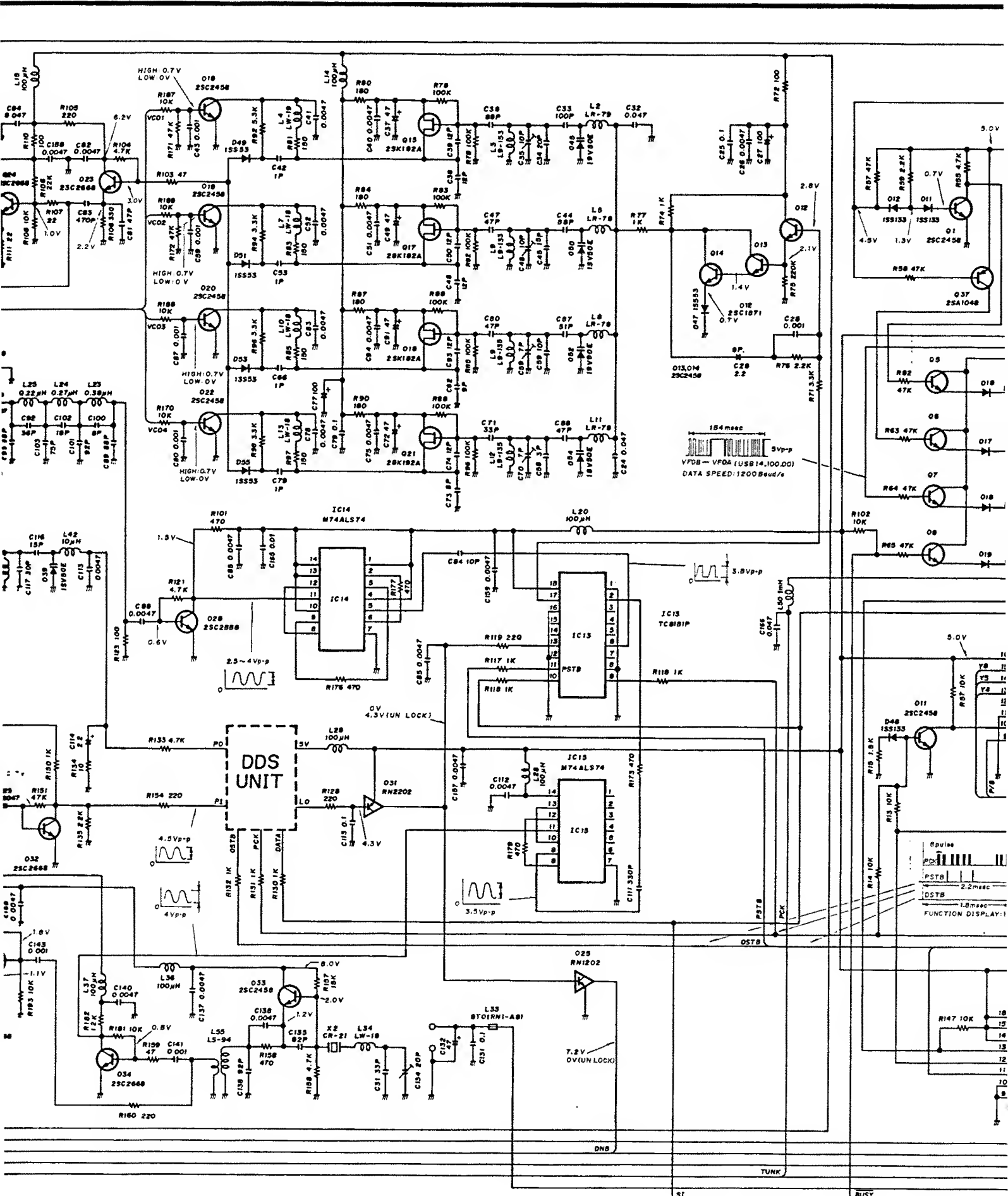

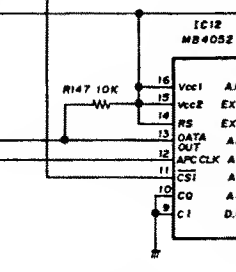
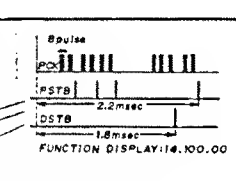
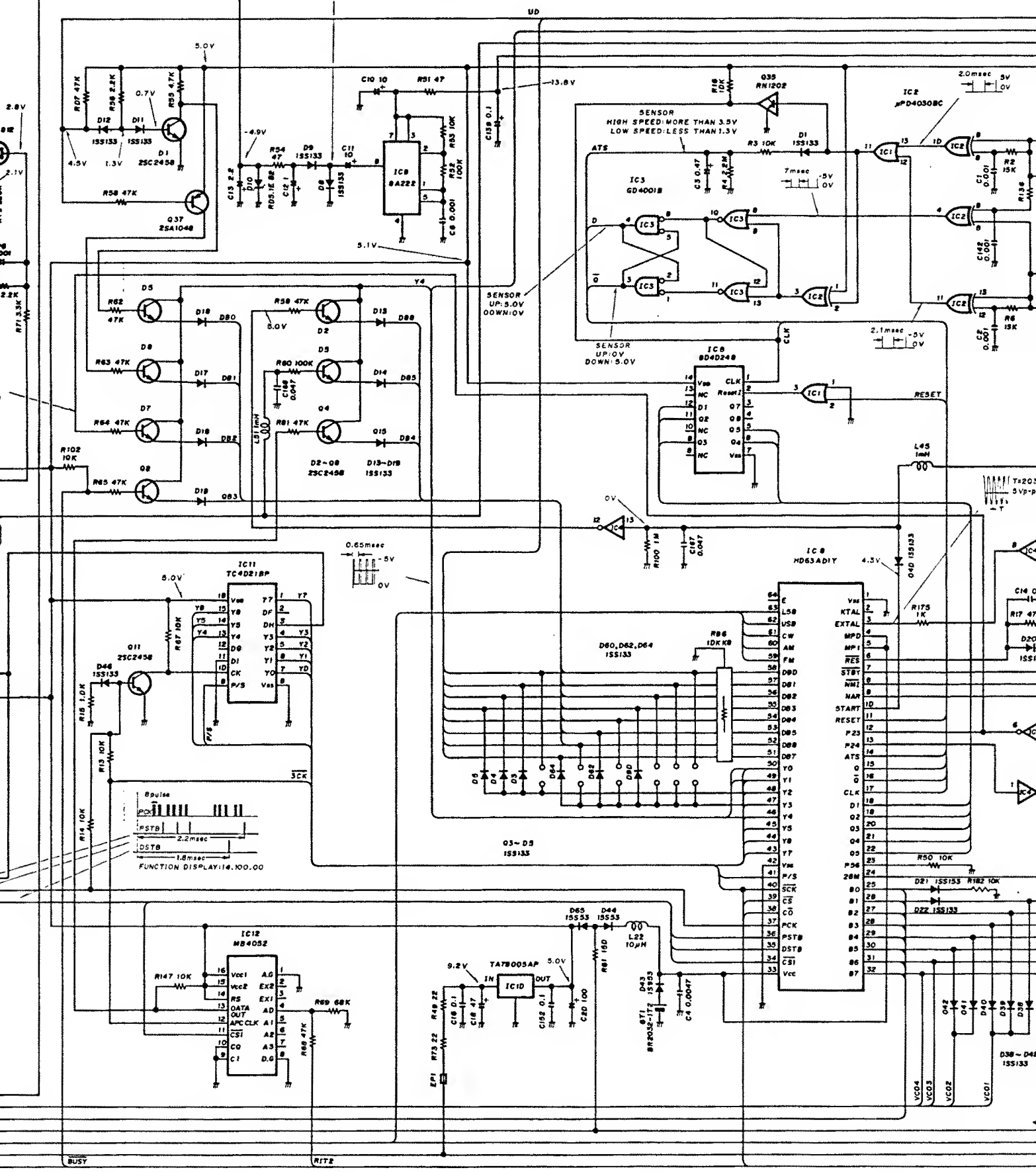
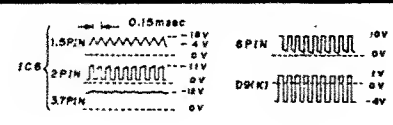

BUS R172

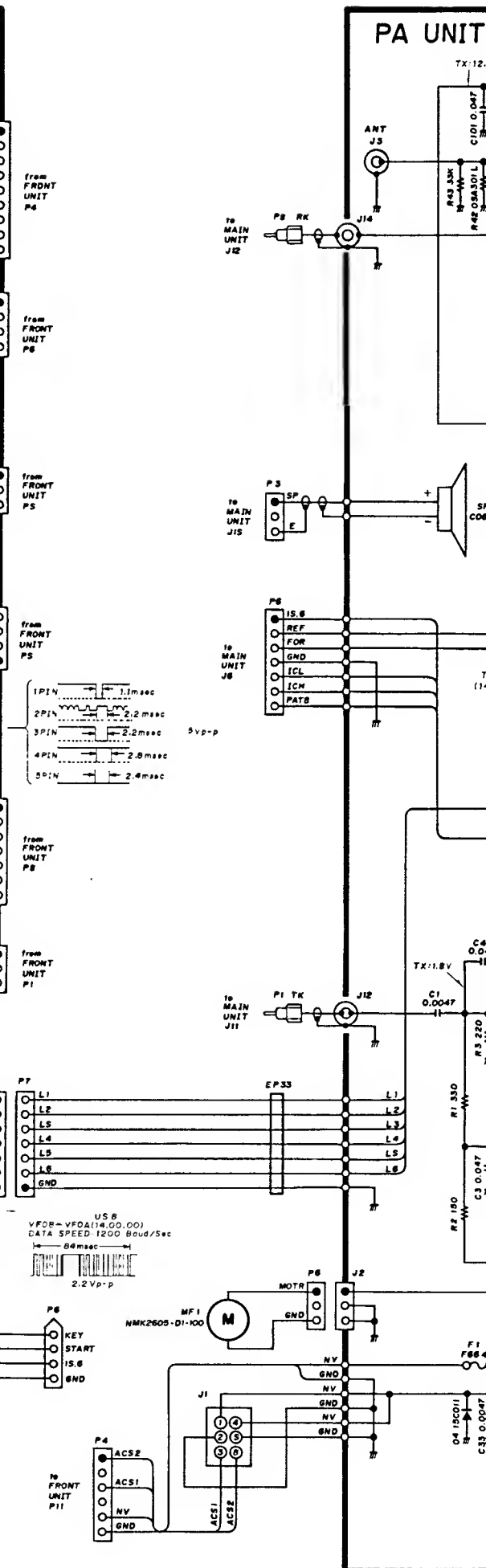
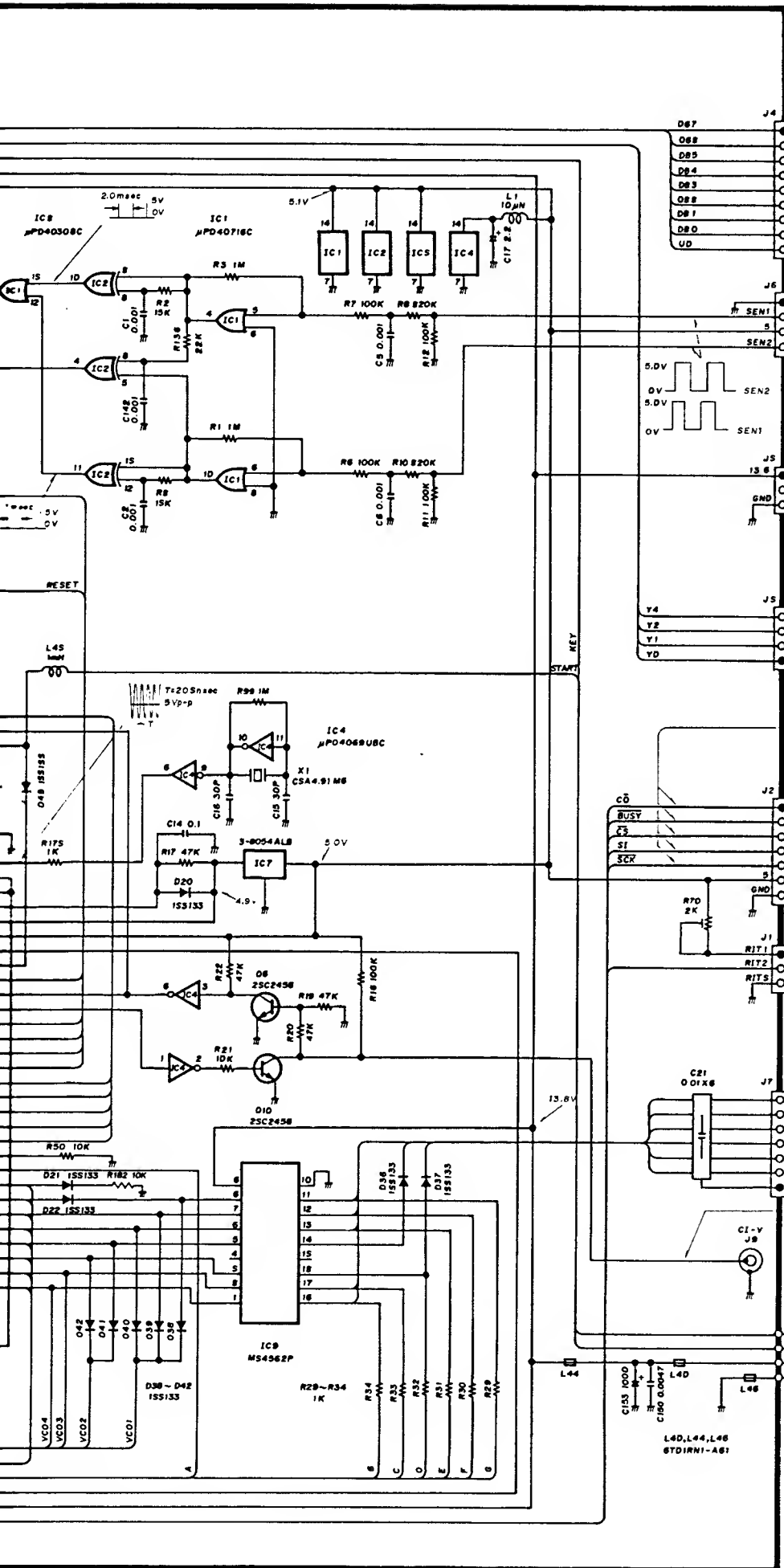

JNIT

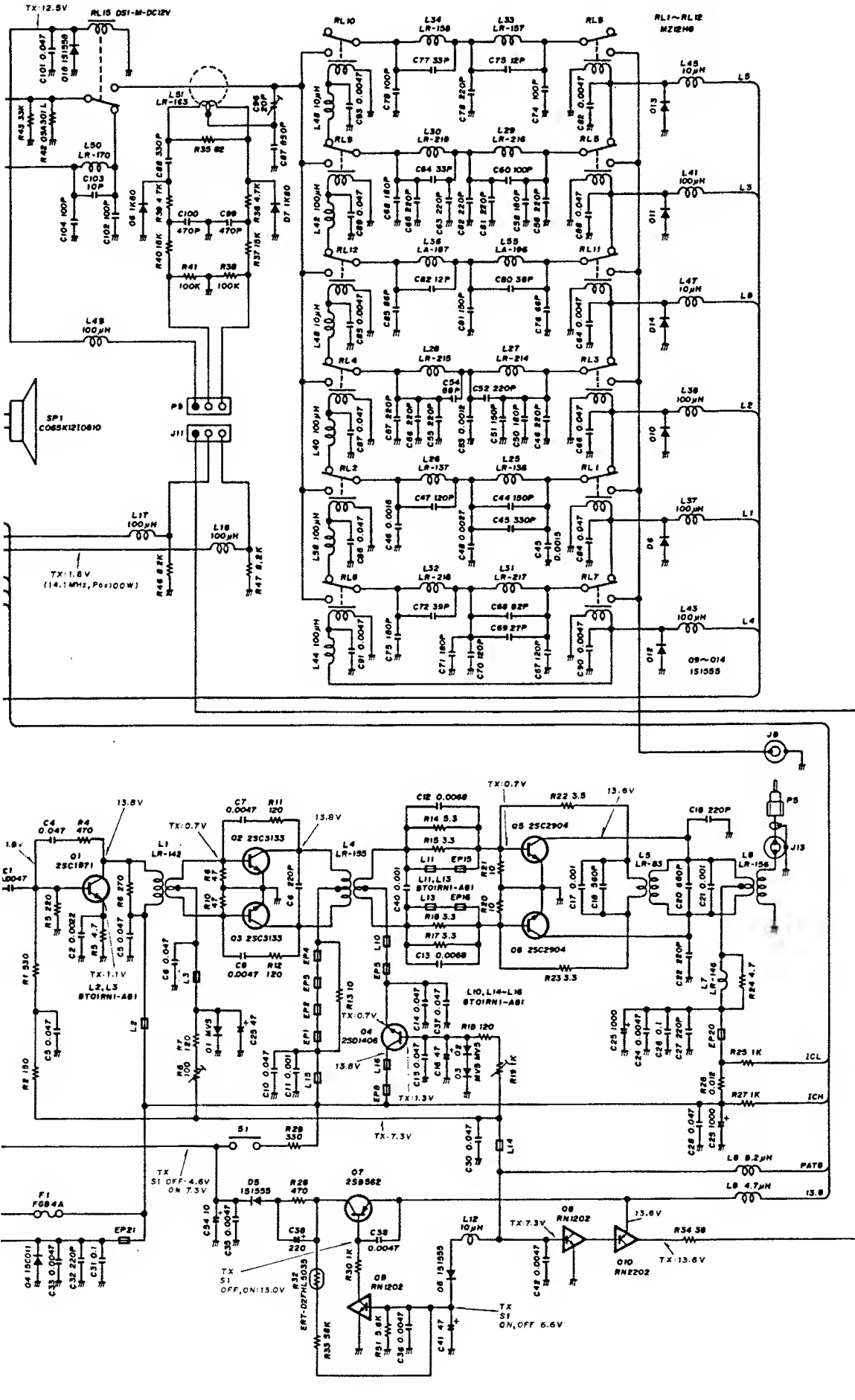

Icom Inc.

6-9-16, Kamihigashi, Hirano-ku, Osaka 547, Japan
Phone: 06 793 5301
Fax : 06 793 0013
Telex : 05277822 ICOMTR J

Icom America Inc.

<Corporate Headquarters>
2380 116th Avenue N.E., Bellevue, WA 98004, U.S.A.
Phone : (206) 454-8155
Fax : (206) 454-1509
Telex : 152210 ICOM AMER BVUE

<Customer Service>
Phone : (206) 454-7619

<Regional Customer Service Centers>
3150 Premier Drive, Suite 126, Irving, TX 75063, U.S.A.
Phone : (214) 550-7525
Fax : (214) 550-7423

1777 Phoenix Parkway, Suite 201, Atlanta, GA 30349, U.S.A.
Phone : (404) 991-6166
Fax : (404) 991-6327

Icom Canada

A Division of Icom America Inc.
3071 #5 Road, Unit 9, Richmond, B.C., V6X 2T4, Canada
Phone : (604) 273-7400
Fax : (604) 273-1900

Icom (Europe) GmbH

Communication Equipment
Himmelgeister Str. 100, 4000 Düsseldorf 1, W. Germany
Phone : 0211 346047
Fax : 0211 333639
Telex : 8588082 ICOM D

Icom (Australia) Pty. Ltd.

Incorporated in Victoria
7 Duke Street, Windsor, Victoria, 3181, Australia
Phone : 03 529 7582
Fax : 03 529 8485
Telex : AA 35521 ICOM AS

Icom (UK) Ltd.

Unit 9, Sea St., Herne Bay, Kent, U.K.
Phone : 0227 363859
Fax : 0227 360155
Telex : 965179 ICOM G

Icom France S.a

120 Route de Revel, BP4063, 31029 Toulouse Cedex, France
Phone : 61. 20. 31. 49
Fax : 61. 34. 05. 91
Telex : 521515 ICOM FRA

Count on us!



KB2LJJ

Radio Mods Database

Icom Inc.

6-9-16, Kamihigashi, Hirano-ku, Osaka 547, Japan

A-5029H-S

Printed in Japan

Copyright © 1989 by Icom Inc.